

Artica AST

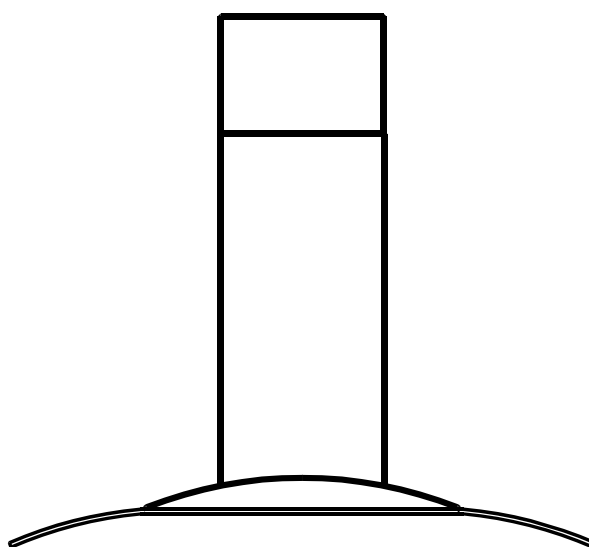

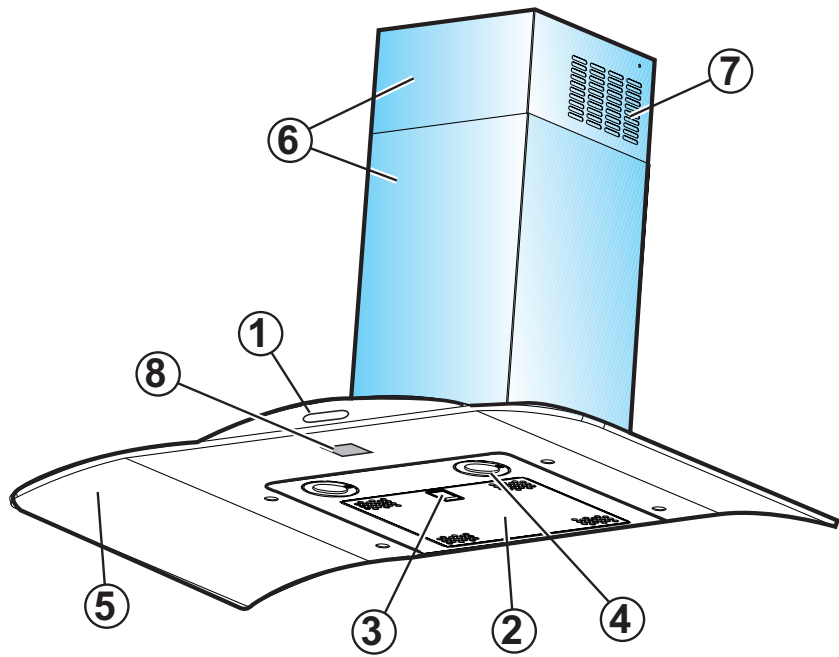

1

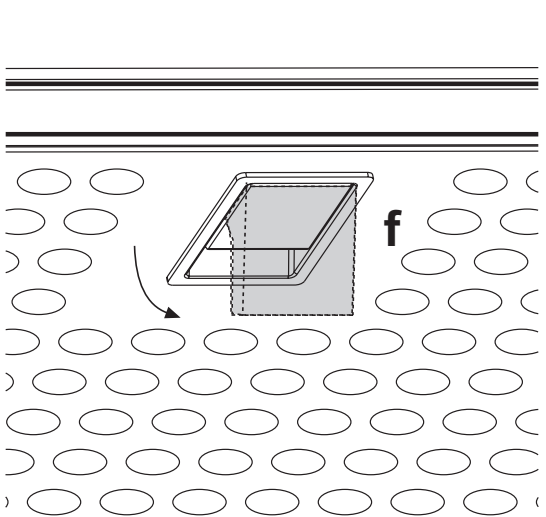

2

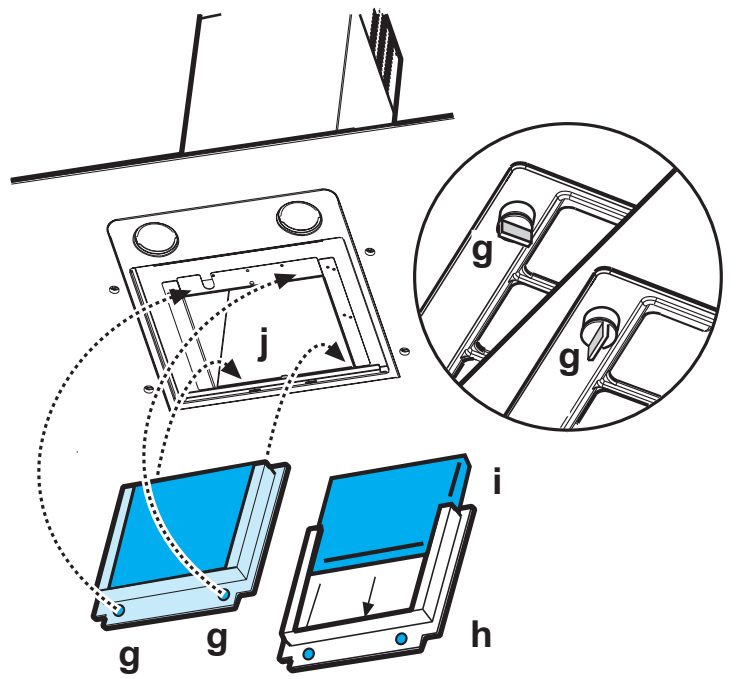

3

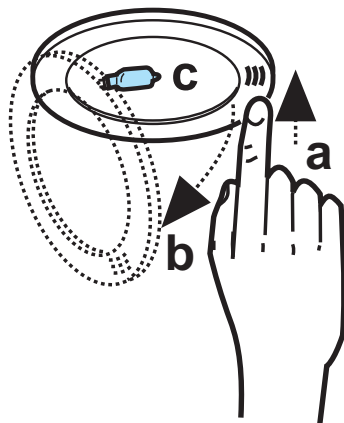

4

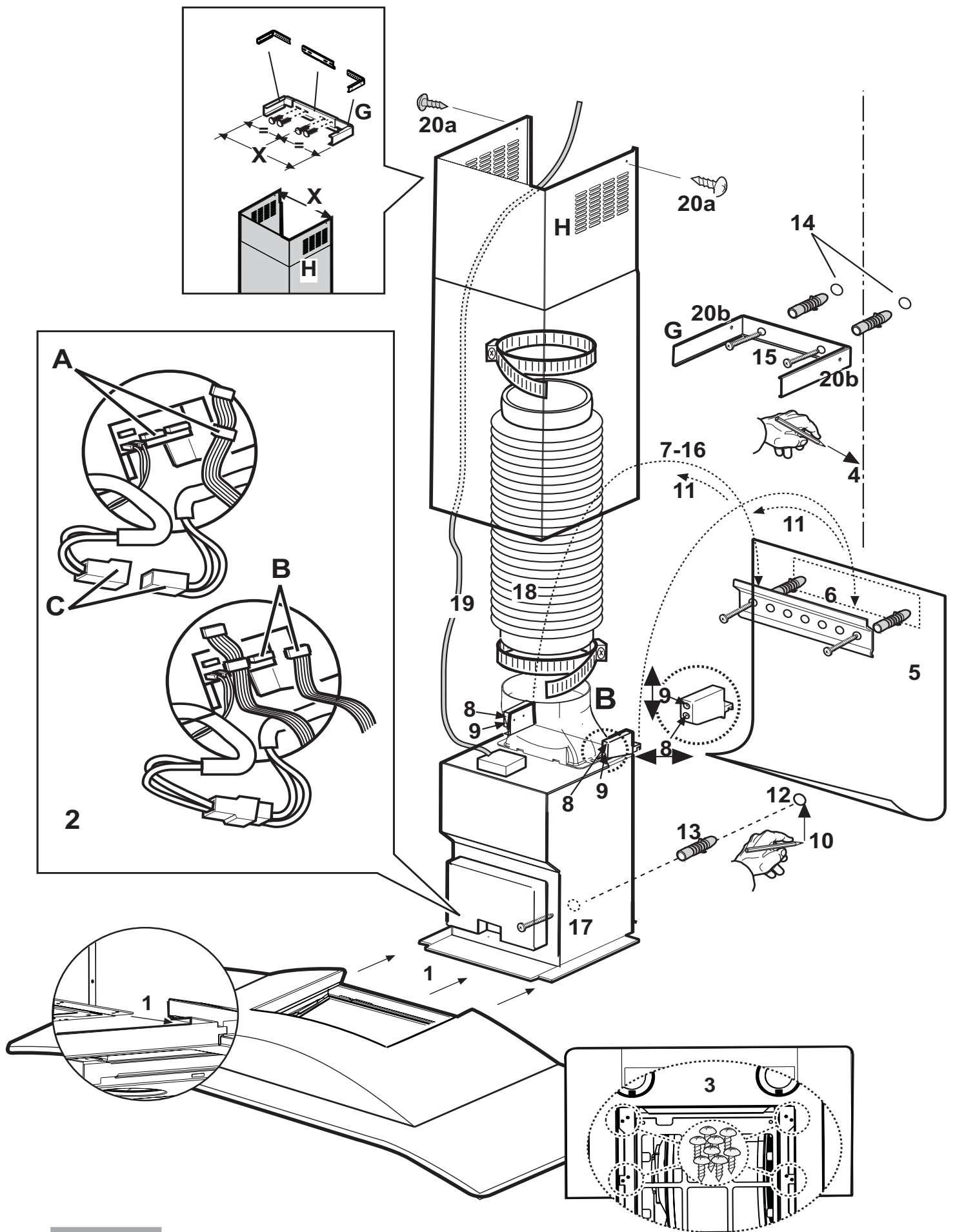

Consult the designs in the front pages referenced in the text by alphabet letters. **Closely follow the instructions set out in this manual.** All responsibility, for any eventual inconveniences, damages or fires caused by not complying with the instructions in this manual, is declined.

The cooker hood must be placed at a minimum distance of 50 cm from the cooking plane for electric cookers and 75cm for gas or mixed cookers.

The hood can be installed above these heights but for optimum performance it should be installed at the distance quoted for the appropriate heat source.

Do not tile, grout or silicone this appliance to the wall. Surface mounting only.

The hood is equipped with a top air outlet **B** for discharge of fumes to the outside (**Ducting version** – exhaust pipe and pipe fixing clamps not provided).

Should it not be possible to discharge cooking fumes and vapour to the outside, the hood can be used in the **filter version**, fitting an activated carbon filter and the deflector **F** on the support (bracket) **G**, fumes and vapours are recycled through the top grille **H** by means of an exhaust pipe connected to the top air outlet **B** and the connection ring mounted on the deflector **F** (exhaust pipe and pipe fixing clamps not provided).

The models with no suction motor only operate in ducting mode, and must be connected to an external suction device (not supplied).

Expansion wall plugs are provided to secure the hood to most types of walls/ceilings. However, a qualified technician must verify suitability of the materials in accordance with the type of wall/ceiling. The wall/ceiling must be strong enough to take the weight of the hood.

Do not tile, grout or silicone this appliance to the wall. Surface mounting only.

Installation - Fig. 5

Preliminary information for installation of the hood Assembling the chimney flue support/bracket (3 parts):

The three parts should be fixed with 4 screws, the support extension is adjustable and should correspond to the internal width of the telescopic chimney flue.

Disconnect the hood during electrical connection, by turning the home mains switch off.

Remove the 2 screws fitted inside the lower part of the hood at the points in which it is fixed to the suction unit (see also operation **3** - remove the grease filter/s).

1. Rest the suction unit on a flat surface and thread the lower part of the hood onto it.

2. Connect the sensor to the small plate on the front of the suction group (**A** – the male and female connectors have an obligatory access) and the lamps (**C**).
Connect the control panel to the small plate located on the front of the suction group (**B** – the male and female connectors have an obligatory access).
3. Fasten the hood to the suction unit using 8 screws.
4. Using a pencil, draw a line on the wall, extending up to the ceiling, to mark the centre. This will facilitate installation.
5. Rest the drilling template against the wall: the vertical centre line printed on the drilling template must correspond to the centre line drawn on the wall, and the bottom edge of the drilling template must correspond to the bottom edge of the hood: bear in mind that, when installation is complete, the underside of the hood must be at least 50 cm above the cooker top in the case of electric cookers, and at least 75 cm above the cooker top in the case of gas or mixed cookers.
6. Rest the support bracket on the drilling template so that it coincides with the dotted rectangle, mark the two outer holes and drill them, remove the drilling template, insert 2 wall plugs and fix the hood support bracket into place using two 5x45mm screws.
7. Hang the hood on the bracket.
8. Adjust the distance of the hood from the wall.
9. Adjust the horizontal position of the hood.
10. From inside the suction unit, use a pencil to mark the hole to be used for final fixing of the hood.
11. Remove the hood from the bracket.
12. Drill at the point marked (Ø8mm - see operation **10**).
13. Insert 1 wall plug
14. Rest the chimney support bracket **G** against the wall, touching the ceiling. Use the support bracket as a drilling template (the small slot formed on the support must coincide with the line drawn on the wall as above – operation 4) and mark 2 holes with a pencil, drill the holes (Ø8mm), insert 2 wall plugs.
15. Fix the chimney support bracket to the wall using two 5x45mm screws.
16. Hook the hood onto the bottom bracket.
17. Fix the hood into its final position on the wall using one 5x45mm screw (ABSOLUTELY ESSENTIAL).
18. Connect a pipe (pipe and pipe clamps not provided, to be purchased separately) for discharge of fumes to the connection ring located over the suction motor unit.
If the hood is to be used in ducting version, the other end of the pipe must be connected to a device expelling the fumes to the outside. If the hood is to be used in filter version, fix deflector **F** to the chimney support bracket **G** using 4 screws, and connect the other end of the pipe to the connection ring on deflector **F**.
19. Make the electrical connections.
20. Apply the chimney stacks and fasten them at the top to the chimney support **G** (**20b**) using 2 screws (**20a**).

21. Slide the bottom section of the chimney down until it completely covers the suction unit and slots into the housing provided on top of the hood.
22. Turn the mains power on again at the central electrical panel and check for correct hood operation. Carry out the SET-UP of the control panel, if necessary. To do this consult the 'Functioning – SET UP' paragraph in the following pages.

Electrical connection

The electrical tension must correspond to the tension noted on the label placed inside the cooker hood. Connect the electrical plug, where provided, to the an easily accessible outlet in conformity with local standards in force. Where an electrical plug is not provided (for direct connection to electrical network) place a standards approved bipolar switch with an aperture distance of not less than 3mm (accessible) from the contacts.

Description of the hood - Fig. 1

1. Control panel
2. Grease filter
3. Grease filter release handle
4. Halogen lamp
5. Vapour screen
6. Telescopic chimney
7. Air outlet (used for filter version only)
8. Sensor

Operation – Model with electronic controls

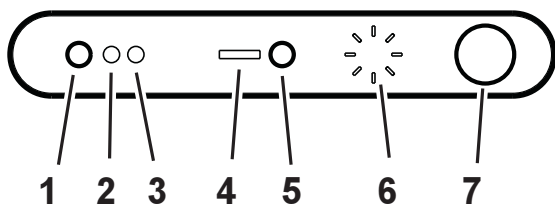

Main Functions

- 1 - ON-OFF lamp button
- 2 - Led signal for anti-grease filter saturation (See the relative cleaning instructions for anti-grease filters).
- 3 - Led signal for active carbon filter saturation (See the relative cleaning instructions for active carbon filters).
- 4 - Led signal for "automatic" operation
- 5 - ON-OFF button for "automatic" operation
- 6 - Functions signal (Led Display).
- 7 - ON/OFF Knob and suction power selection.

List of Functions

To switch the cooker hood to (ON) depress knob **7**
The operation of button **5** is enabled and the wording "Sensor" will appear, the cooker hood will set at "Manual Stand-By".

To switch the cooker hood to (OFF) depress knob **7** again; if the cooker hood is set in the "automatic" operation mode then depressing knob **7** once will launch the cooker hood to "manual Stand-By" depressing the knob again will switch the cooker hood to (OFF).

Attention! When the cooker hood is switched (OFF) all the functions are disabled.

To switch on the lamps depress button **1**.

To switch off the lamps depress button **1** again.

To increase the suction speed rotate knob **7** clockwise and set the desired speed (**1, 2, 3** or **intensive**).

Attention

The intensive suction speed is timed for 5 minutes after which the cooker hood returns to the 2nd speed.

The led number (**1, 2** or **3**) will appear on the Display, which is equivalent to the suction speed set **plus** a red led will also appear when the suction speed is set at **intensive**.

The other display led's will turn on alternatively in proportion to the suction power setting.

To decrease the suction speed rotate the knob anticlockwise (**Intensive, 3, 2, 1, Stand-by**)

Filter Saturation Signal

The cooker hood is provided with an electronic device which signals the necessity to clean and/or replace the filters (Grease or Active Carbon).

Attention!

The saturation signal device for the active carbon filter is disabled, the enabling (or disabling) function is performed in the **SET-UP** operation (see instructions at the bottom of the page).

Grease filter saturation signal

The LED signal **2** will turn on.

Active Carbon filter saturation signal

The LED signal **3** will turn on.

Attention! The signal will not appear when the cooker hood is switched (OFF) or in **stand-by** mode.

Reset the Filter saturation signal (to be carried out ONLY after having cleaned and/or replaced the filters):

Set the cooker hood to **stand-by** depress button **7** until the sound of the beep and upon the turning off of the wording **sensor**.

Automatic Operation

The cooker hood always sets at "manual operation", depressing button **5** the cooker hood sets to "automatic operation": the wording **Sensor** turns on (from white to orange); the cooker hood starts up and regulates the speed only if the **sensors**, of which the cooker hood is equipped, detect any variations in the environment conditions. The led signals for function **6** will turn on in sequence at a speed that varies the suction speed that it sets automatically on the basis of the sensors readings. Depressing button **5** again and rotating knob **7** the cooker hood returns to "manual operation".

Attention! The sensors **automatically calibrate** every half hour, and on the basis of the data detected will determine the automatic turning **on** or **off** of the cooker hood.

In certain cases (where the environment temperature increases or decreases for other reasons) it may be necessary to carry out a manual calibration for the sensor.

The **manual calibration** of the sensor may be performed in the **SET-UP** operation.

Safety

When the cooker hood is in manual stand-by mode and the sensors detect an excessive increase in the temperature, the cooker hood will set to “**automatic operation**” and if the environment conditions require it, then the motor will also start up.

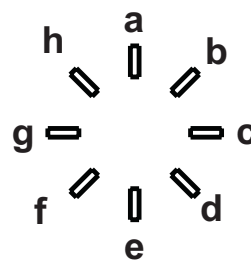

SET-UP

To access the set-up mode

- Depress knob **7** and switch the cooker hood to (**OFF**-all the led's are turned off).
- Keep **button 5** depressed and depress knob **7**.

To exit the SET-UP mode

- Depress button **7** again.

To enable the saturation device for the active carbon filter

Upon entering the **SET-UP** mode, turn knob **7** clockwise until the led (**e**) turns on. If the led is **red**, depress button **5** once, the led (**e**) will turn **green** which will indicate that the saturation signal device has been enabled for active carbon filter, depress again to disable (led (**e**) will turn red).

To carry out manual calibration

Upon entering the **SET-UP** mode, turn knob **7** clockwise for one click (about 10°) until the led (**c**) turns on (red led). Depress button **7** to carry out manual calibration.

Additional information:

When rotating the knob clockwise in **SET-UP** mode, if the led (**g**) turns on *then* ignore it.

If the hood fails to operate correctly, briefly disconnect it from the mains power supply for almost 5 sec. by pulling out the plug. Then plug it in again and try once more before contacting the Technical Assistance Service.

Use the high suction speed in cases of concentrated kitchen vapours. It is recommended that the cooker hood suction is switched on for 5 minutes prior to cooking and to leave in operation during cooking and for another 15 minutes approximately after terminating cooking.

Maintenance

Prior to any maintenance operation ensure that the cooker hood is disconnected from the power supply.

Cleaning

The cooker hood should be cleaned regularly internally and externally.

For cleaning use a cloth moistened with denatured alcohol or neutral liquid detergents. Avoid abrasive detergents.

Warning:

Failure to carry out the basic standards of the cleaning of the cooker hood and replacement of the filters may cause fire risks.

Therefore we recommend observing these instructions.

Grease filter

This must be cleaned once a month using non aggressive detergents, either by hand or in the dishwasher, which must be set to a low temperature and a short cycle.

When washed in a dishwasher, the grease filter may discolour slightly, but this does not affect its filtering capacity. To remove the grease filter, pull the spring release handle **(f)** - (Fig. 2).

Charcoal filter (filter version only)

It absorbs unpleasant odours caused by cooking.

The charcoal filter can be washed once every two months using hot water and a suitable detergent, or in a dishwasher at 65°C (if the dishwasher is used, select the full cycle function and leave dishes out).

Eliminate excess water without damaging the filter, then remove the mattress located inside the plastic frame and put it in the oven for 10 minutes at 100° C to dry completely. Replace the mattress every 3 years and when the cloth is damaged.

Remove the filter holder frame by turning the knobs **(g)** 90° that affix the chimney to the cooker hood **(Fig. 3)**.

Insert the pad **(i)** of activated carbon into the frame **(h)** and fit the whole back into its housing **(j)**.

Replacing lamps - Fig. 4

Access the light compartment

press on the lamp cover and release to open.

Warning!

Prior to touching the light bulbs ensure they are cooled down.

Replace the damaged light bulb.

Only use halogen bulbs of 20W max (G4), making sure you do not touch them with your hands.

Close the lamp cover (it will snap shut).

If the lights do not work, make sure that the lamps are fitted properly into their housings before you call for technical assistance.

Caution

This appliance is designed to be operated by adults. Children should not be allowed to tamper with the controls or play with the appliance.

Do not use the cooker hood where the grill is not correctly fixed! The suctioned air must not be conveyed in the same channel used for fumes discharged by appliances powered by other than electricity. The environment must always be adequately aerated when the cooker hood and other appliances powered by other than electricity are used at the same time. Flambé cooking with a cooker hood is prohibited. The use of a free flame is damaging to the filters and may cause fire accidents, therefore free flame cooking must be avoided. Frying of foods must be kept under close control in order to avoid overheated oil catching fire. Carry out fumes discharging in accordance with the regulations in force by local laws for safety and technical restrictions.