

elica
SEGNÒ D'ARIA
DR Cooker Hoods Ltd

Ventilation Ducting

elica
Collection



Choosing and Installing the Correct Cooker Hood Ducting

Because it is normally hidden, a ducting system is often not considered an important part of the construction or refurbishment of a building. However, the importance of the correct ducting is slowly becoming recognised by the building industry.

It is not always the fault of the cooker hood manufacturer when dreams of fresh kitchens and low noise are not achieved. It can often be that the size or configuration of ducting has been incorrectly selected by the installer or system designer.

As it cannot be seen, air movement is often made more complicated than it actually is. Air moves just as water moves and it is sometimes useful to visualise a problem by substituting it with water.

In ventilation installations the aim is normally to move the air from its source to the outside of the house as efficiently and quietly as possible. It is, therefore, common sense that to do this effectively, the shorter the distance that the air has to travel, the quicker the aim is achieved. It is also common sense that if an obstacle is put in the way, such as a bend, the process will become more difficult as the air will lose its momentum and require more powerful assistance in order to achieve the aim.

Cooker hoods vary in power just as cars do and the results are reflected in much the same way. A high performance/specification car should be quieter, last longer and generally provide the driver with more comfortable and satisfactory results. However, to ensure this, the car needs a straight smooth road on which to travel effectively. The road for the air to travel when using a cooker hood is the ducting. Again, it is common sense that a

more powerful cooker hood would need a more efficient duct – a Rolls Royce owner would not consider driving their car off-road! It is worth remembering that many cooker hood manufacturers' guarantees will be invalidated if the correct size of ducting is not used to match the power of the cooker hood.

A few key installation guidelines can be applied to help ensure that the ducting selection is correct and installed in a way that optimises the cooker hoods' performance.

- Choose the shortest and most direct route to outside.
- Ensure that bends are kept to a minimum.
- Check the extraction capability and connection size of the cooker hood and choose an appropriate size of ducting. Refer to the cooker hood manufacturer for performance ratings and specifications.
- A round duct provides optimum airflow performance and should be used if installation space allows.
- Rectangular or flat channel ducting is an excellent alternative when space is restricted. Its low profile enables the ducting to be easily concealed in the ceiling void or along the top of wall units.
- A rigid duct is more efficient than a flexible duct and should be used whenever possible.
- If flexible hose is used, the hose should remain taut and as straight as possible.

- Provision should be made for make up air. In most dwellings this is catered for by natural leakage. However, some high performance products may require the installation of an air supply set.





Important

If installing a cooker hood in a room containing an open-flued fuel-burning appliance (ie non-balanced flue), there must be sufficient replacement air to prevent fumes being drawn back down the flue when the cooker hood is set to maximum extract.

Exhaust air must not be discharged into a flue used for exhausting fumes from appliances supplied with energy other than electricity. When deciding the method for exhaust air discharge and intake flow rates, the requirements of all relevant authorities must be strictly adhered to.

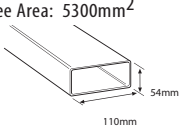
If the duct passes through an unheated roof void the duct should be insulated to reduce the formation of condensation. A vertical duct should also be installed with a weatherproof roof cowl of sufficient free area for the air volume. A condensation trap must be fitted in order in order to alleviate condensation build-up. Horizontal ducts should fall away from the cooker hood.

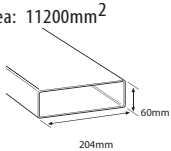
- Made from flame retardant self extinguishing materials to conform to US fire standard UL94 V2 and also to DIN 4102 B1
- Maximum working temperature of 60 °C
- Bends and adapters meet most installation requirements
- Lightweight and easy to install

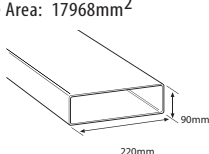
	Size	Application	Dimensions	Cross Section
 <p>Up to 250m³ / hr</p>	4" (100mm)	Particularly suitable for applications requiring lower extraction rates, such as the ventilation of lower powered cooker hood with 100mm exhaust spigots, domestic bathrooms and internal WCs. Provides efficient ducting for short, simple runs.	Flat channel outer dimensions are 110 x 54mm and fit into system parts sockets. Minimum space required: 115 x 60mm	Free Area: 5300mm ² 
 <p>Up to 500m³ / hr</p>	5" (125mm)	Ideal for the ducting of medium powered kitchen cooker hoods and fans with 125mm round exhaust spigots. Highly efficient even for long runs, and with appliances of a high extraction rate.	Flat channel outer dimensions are 204 x 60mm and fit into system parts sockets. Minimum space required: 210 x 65mm	Free Area: 11200mm ² 
 <p>500m³ / hr & above</p>	6" (150mm)	Ideal for the ducting of very high powered cooker hoods, especially those with 150mm exhaust spigots. This highly efficient rectangular duct has a comparable airflow performance of a 150mm round duct, but its lower profile provides the fitter or system designer with greater installation flexibility.	Flat channel outer dimensions are 220 x 90mm and fit into system part sockets. Minimum space required: 227 x 97mm	Free Area: 17968mm ² 

4" (100mm) nominal or rectangular equivalent

One of these ducting kits will be ideal for most situations. They are designed for cooker hoods with 100mm dia. ducting outlets and for bathroom extraction systems. The flexible hose kits may also be used for tumble dryers.

Each part may be ordered separately, so to extend any of these kits, simply order the appropriate kit plus extra part.

Please ring for advice regarding special applications such as ducting into or through chimneys.



Cooker hoods up to 250 m³ /hr

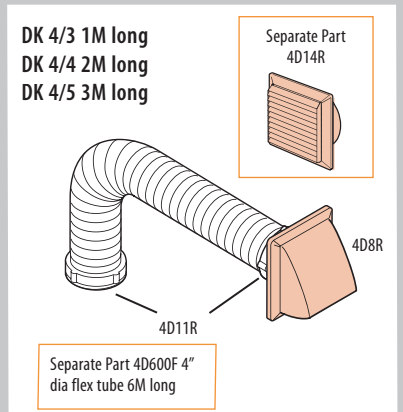
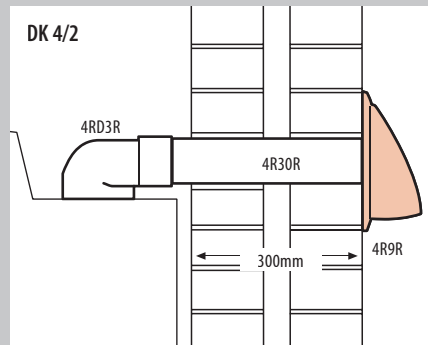
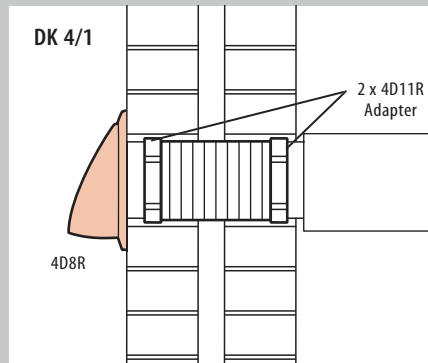

DK 4/9

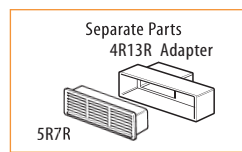

4R9R
154 x 154mm
Spigot 110 x 54 I.D.

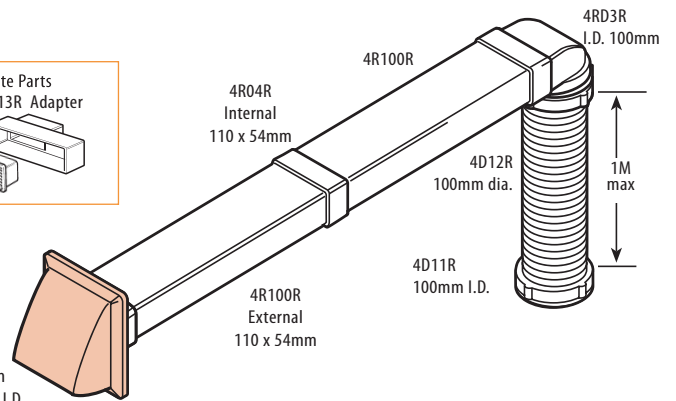

4D17R to connect 5" duct to 4" spigot



4D5D



4D30-55R

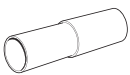

4D100R

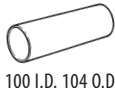

100 I.D. 104 O.D.

4R5R



4R6R



4RD2R



4D18D



4D15D



4R16R



4D150A/4D300A



4DALUCLIP



4D300F/4D600F



UB41



Suitable for 100, 125, 150 & 160, round pipe with 500mm sq. lead flashing skirt.

4RD2R	Rectangular/Round Connector	4D18D	Round to Round 90° Bend
4RD3R	Round/Rectangular Elbow with Socket	4D300F	Round Flexi Hose 3M Long
4R30R	Rectangular Rigid Duct 300mm Long	4D600F	Round Flexi Hose 6M Long
4RD03R	Round/Rectangular Elbow with Spigot	4D150A	Round Aluminium Duct 1.5M Long
4R04R	Rectangular Connector	4D300A	Round Aluminium Duct 3M Long
4R5R	Rectangular Horizontal Elbow	4R300F	Rectangular Flexi Hose 3M Long
4R6R	Rectangular Vertical Elbow	4D100R	Round Pipe 1M Long
4R7R	Rectangular Duct Retaining Clip	4R100R	Rectangular Rigid Duct 1M Long
4D8R-BR	Cowled Wall Vent Round Socket - Brown	4DCLIP	Hose Clip
4D8R-WH	Cowled Wall Vent Round Socket - White	4DALUCLIP	Aluminium Duct Clip
4R9R-BR	Cowled Wall Vent Rectangular Socket - Brown	TAPE33	33M PVC Adhesive Tape
4R9R-WH	Cowled Wall Vent Rectangular Socket - White	4D30-55R	Round Adjustable Pipe
4D11R	Threaded Hose Adapter 100mm I.D.	4D14R	Fixed Louvred Grille Round Socket
4D12R	Threaded Hose Adapter 100mm O.D.	4D17R	4" to 5" Adapter
4R13R	Adapter (4R100R-5R7R) outlet	4D5D	Universal Offset Ducting Spigot
4D15D	Round Pipe Connector	UB41	Universal Roof Vent
4R16R	Round Pipe Connector + Damper		

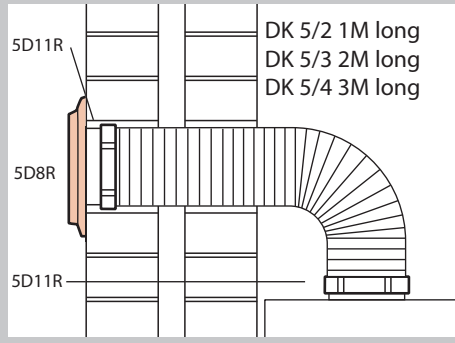
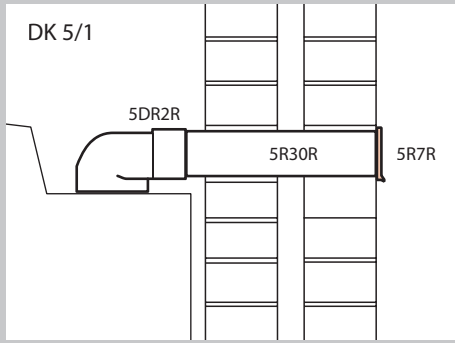

5" (125mm) nominal
or rectangular equivalent

One of these ducting kits will be ideal for most situations. They are designed for cooker hoods with 125mm dia. ducting outlets and for bathroom extraction systems.

Each part may be ordered separately, so to extend any of these kits, simply order the appropriate kit plus extra part.



Cooker hoods up to 500 m³ /hr

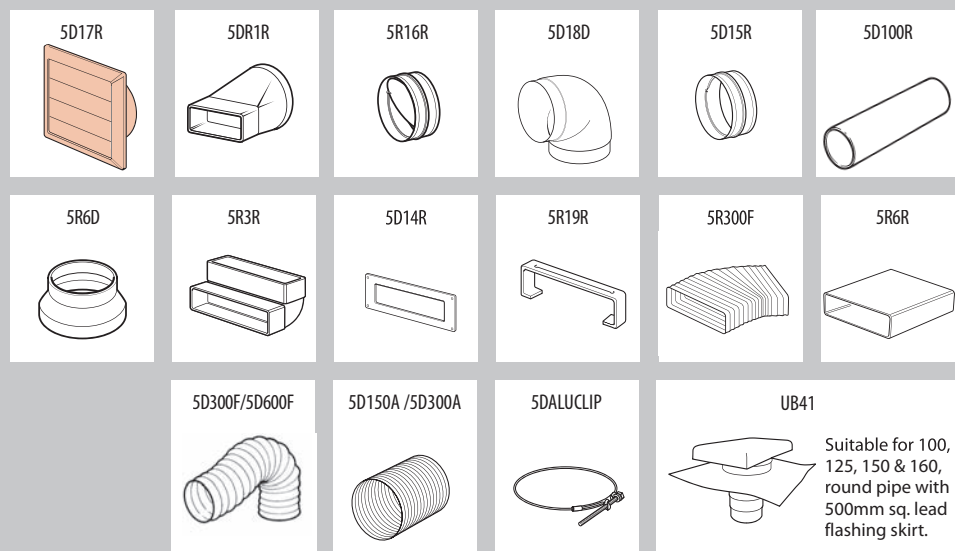
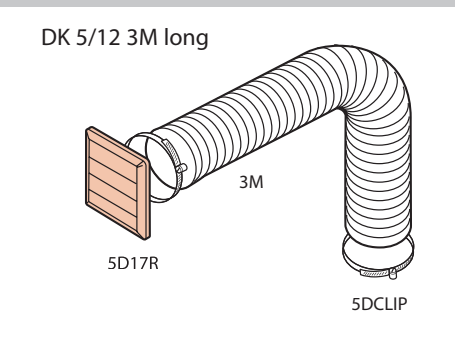
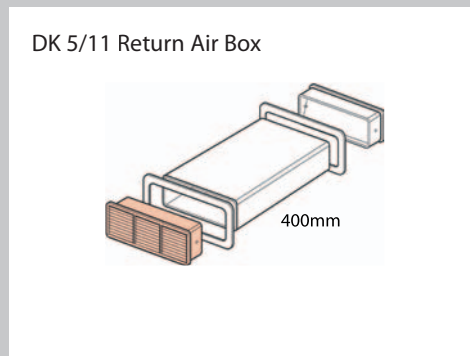
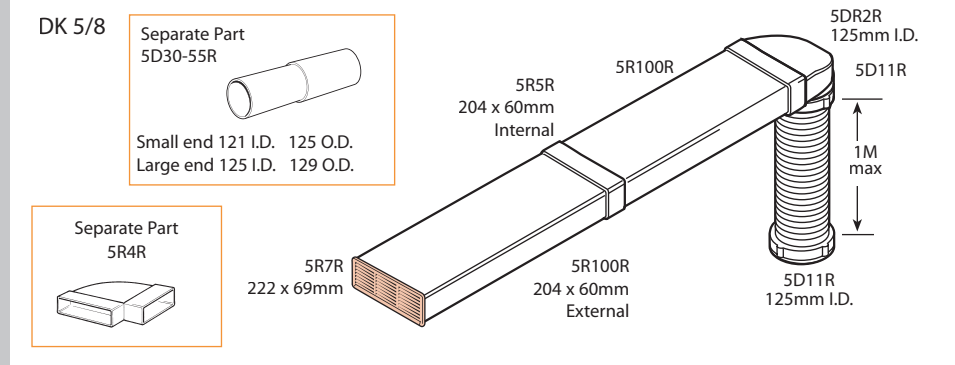

5DR1R	Rectangular/Round Connector	5R7R	Wall Vent Rectangular Outlet	5D300A	Round Aluminium Duct 3M Long
5DR2R	Round/Rectangular Vertical Elbow	5D8R	Wall Vent Round Outlet	5DCLIP	Hose Clip
5R3R	Rectangular Vertical Elbow	5D11R	Threaded Hose Adapter	5DALUCLIP	Aluminium Duct Clip
5R100R	Rectangular Rigid Duct 1M Long	5D14R	Wall Plate	TAPE33	33M PVC Adhesive Tape
5R30R	Rect Rigid Duct 300mm Long	5D15R	Connector for Round Rigid Duct	5D18D	Round to Round 90° Bend
5D30-55R	Round Adjustable Telescopic Pipe	5D16R	Round Pipe Connector and Damper	5R300F	Rectangular Flexi Hose 3M Long
5R4R	Rectangular Horizontal Elbow	5D17R	Wall Outlet with Gravity Flap	5R19R	Flat Channel clip
5R40R	Rectangular Rigid Duct 400mm Long	5D100R	Round Pipe 1M Long	UB41	Universal Roof Vent
5R5R	Connector Rectangular Rigid Duct	5D300F	Round Flexible Hose 3M Long		
5R6R	Connector Rectangular Flexi Duct	5D600F	Round Flexi Hose 6M Long		
5R6D	125mm to 150mm Adapter	5D150A	Round Aluminium Duct 1.5M Long		

**6" (150mm) nominal
or rectangular equivalent**

Maximum airflow performance can be achieved with 150mm dia. ducting. Particularly suitable for larger fans and more powerful cooker hoods.

Separate parts can be ordered using appropriate code. Please ring for further advice.



Cooker hoods 500 m³/hr and above

- 6D1R Louvred Wall Vent
- 6D2R Cowled Wall Outlet
- 6D300F 3 metre 6" (150mm) Flexi Hose
- 6D600F 6 metres 6" (150mm) Flexi Hose
- 6D150A Round Aluminium Duct 1.5M Long
- 6D300A Round Aluminium Duct 3M Long
- 6DCLIP Hose Clip 6" (150mm)
- 6D4R Round/Rectangular Elbow (150mm round/
6R100R 150mm Rectangular)
- 6D11R Threaded Hose Connector (150mm)
- 6D16R Round Pipe Connector and Damper
- 6D21R Round Pipe Connector
- 6D17R Wall Outlet with Gravity Flap
- 6D18D Round to Round 90° bend
- 6DR1R Rectangular/Round Connector
- 6R6R Connector for Rectangular Rigid Ducting
- 6R8R Horizontal Bend
- 6R9R Vertical Bend
- 6R100R Rectangular Rigid Duct 100cm Long
- 6R19R Flat Channel Clip (one needed either side)
- 6D100R Round Rigid Pipe 100cm Long
- 6R300F Flexible Rectangular Hose 3M Long
- 6R7R Double Airbrick
- 6R3R Double Airbrick Adapter
- 6DALUCLIP Aluminium Duct Clip
- UB41 Universal Roof Vent

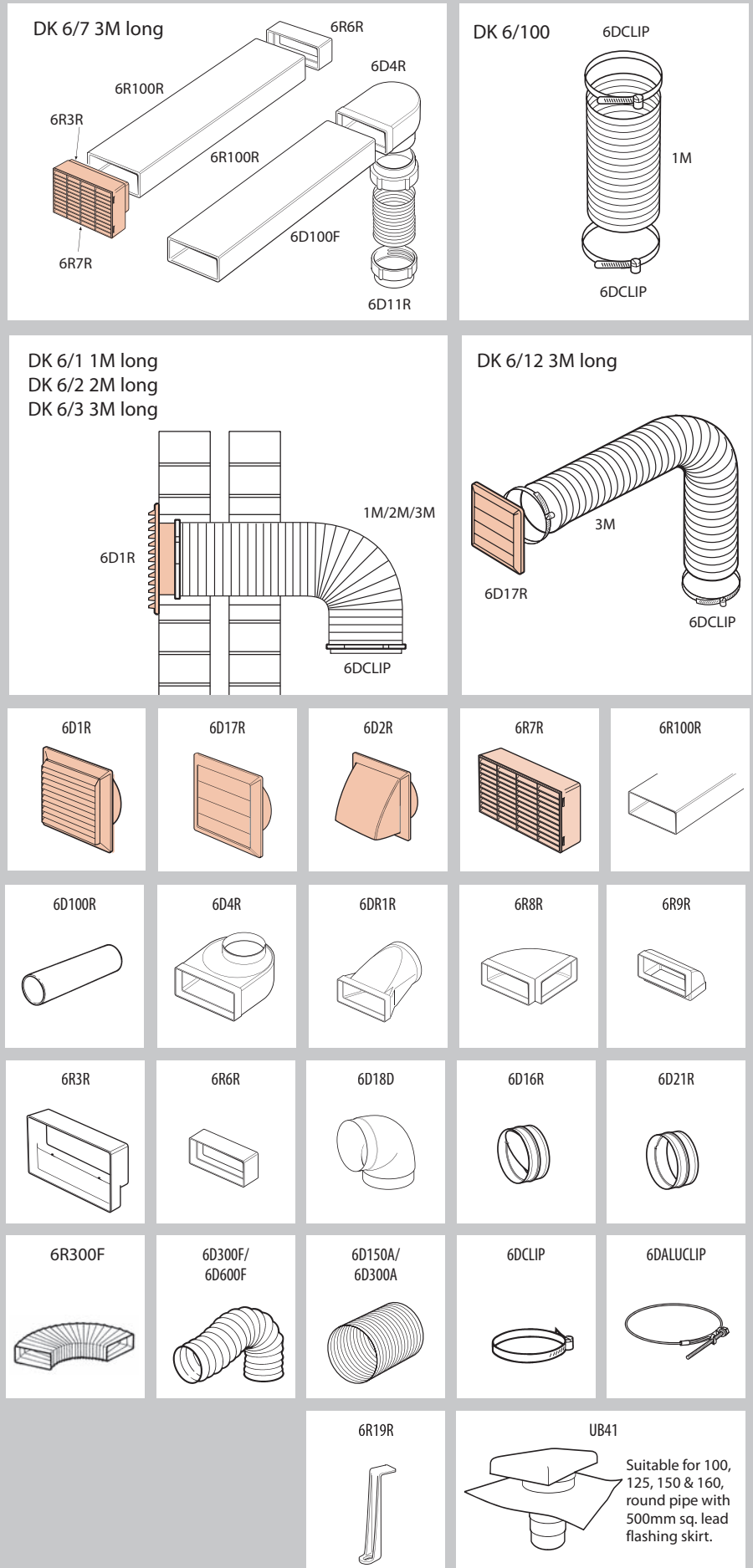



DR Cooker Hoods Ltd
2 Alpha Road
Aldershot
Hampshire
GU12 4RG

Tel: (01252) 351111
Fax:(01252) 311608
email:sales@drcookerhoods.co.uk
www.elica.co.uk

Issue 0804