

ISTRUZIONI PER L'INSTALLAZIONE, LA MANUTENZIONE E L'USO DELLA CAPPA  
INSTRUCTION, USE AND INSTALLATION MANUAL  
INSTALLATIONSANLEITUNG, GEBRAUCH UND WARTUNG DER ABZUGSHAUBEN  
INSTRUCTIONS POUR L'INSTALLATION, L'ENTRETIEN ET L'USAGE DE LA HOTTE  
INSTRUCCIONES PARA LA INSTALACIÓN, EL MANTENIMIENTO Y EL USO DE LA CAMPANA  
INSTRUÇÕES PARA A INSTALAÇÃO, A MANUTENÇÃO E USO DA COIFA  
UPUSTVA ZA INSTALACIJU, ODRŽAVANJE I UPOTREBU NAPE  
INSTRUKTIONER VEDRØRENDE INSTALLATION, VEDLIGEHOLDELSE OG BRUG AF EMHÆTTE  
LIESITUULETTIMEN ASENNUKSEN-, KÄYTTÖ- JA HUOLTO-OHJEET  
ΟΔΗΓΙΕΣ ΓΙΑ ΤΗΝ ΕΓΚΑΤΑΣΤΑΣΗ, ΣΥΝΤΗΡΗΣΗ ΚΑΙ ΧΡΗΣΗ ΤΟΥ ΑΠΟΡΡΟΦΗΤΗΡΑ  
INSTRUKSJONER FOR INSTALLASJON, VEDLIKEHOLD OG BRUK AV KJØKKENVIFTEN  
INSTRUCTIES VOOR HET INSTALLEREN, ONDERHOUDEN EN GEBRUIKEN VAN DE KAP  
INSTRUKCJE DOTYCZĄCE INSTALACJI, KONSERWACJI I UŻYTKOWANIA WYCIĄGU  
INSTRUCȚIA DE INSTALARE ȘI CONSERVARE A EXTRACTORULUI  
INSTRUKCIJE ZA MONTAZU KONZERVACIJU I UPOTREBU ASPIRATORA  
NÁVOD NA INŠTALÁCIU, ÚDRŽBU A POUŽITIE ODVÁDZAČA DYMU  
NAVODILA ZA INSTALACIJO, VZDRŽEVANJE IN UPORABO NAPE  
INSTALLATIONS-, UNDERHÅLLS- OCH BRUKSANVISNING FÖR FLÄKT  
AZ ELSZÍVÓ BERENDEZÉS HASZNÁLATI, TELEPÍTÉSI ÉS KARBANTARTÁSI ÚTMUTATÁSA  
NÁVOD K INSTALACI, ÚDRŽBĚ A POUŽITÍ ODSAVAČE PAR  
ИНСТРУКЦИЯ ПО ПРОИЗВОДСТВУ МОНТАЖА, КОНСЕРВАЦИИ И ПОЛЬЗОВАНИЯ  
ВЫТЯЖНЫМ УСТРОЙСТВОМ  
油烟机安装、维护及使用指南  
ІНСТРУКЦІЯ З ІНСТАЛЯЦІЇ, КОНСЕРВАЦІЇ ТА ЕКСПЛУАТАЦІЇ ВИТЯЖКИ ДИМОХІДНА МОДЕЛЬ

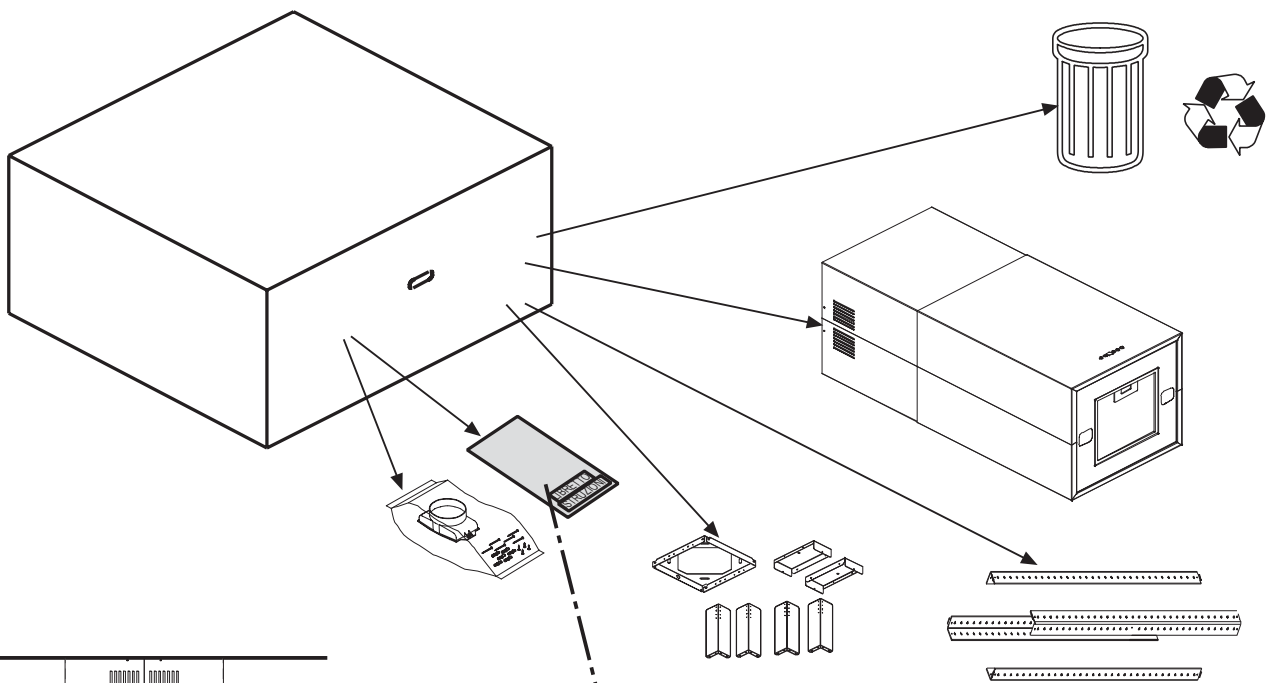

ISTRUZIONI PER L'INSTALLAZIONE, LA MANUTENZIONE E L'USO DELLA CAPPA  
 INSTRUCTION, USE AND INSTALLATION MANUAL  
 INSTALLATIONSANLEITUNG, GEBRAUCH UND WARTUNG DER ABZUGSHAUBEN  
 INSTRUCTIONS POUR L'INSTALLATION, L'ENTRETIEN ET L'USAGE DE LA HOTTE  
 INSTRUCCIONES PARA LA INSTALACIÓN, EL MANTENIMIENTO Y EL USO DE LA CAMPANA  
 INSTRUÇÕES PARA A INSTALAÇÃO, A MANUTENÇÃO E USO DA COIFA  
 UPUSTVA ZA INSTALACIJU, ODRŽAVANJE I UPOTREBU NAPE  
 INSTRUKCJE DOTYCZĄCE INSTALACJI, KONSERWACJI I UŻYTKOWANIA WYCIĄGU  
 INSTRUȚIA DE INSTALARE ȘI CONSERVARE A EXTRACTORULUI  
 INSTRUKCIJE ZA MONTAZU KONZERVACIJU I UPOTREBU ASPIRATORA  
 NÁVOD NA INŠTALÁCIU, ÚDRŽBU A POUŽITIE ODVÁDZAČA DYMU  
 NAVODILA ZA INSTALACIJO, VZDRŽEVANJE IN UPORABO NAPE  
 INSTALLATIONS-, UNDERHÅLLS- OCH BRUKSANVISNING FÖR FLÅKT  
 AZ ELSZÍVŐ BERENDEZÉS HASZNÁLATI, TELEPÍTÉSI ÉS KARBANTARTÁSI ÚTMUTATÁSA  
 NÁVOD K INSTALACII, ÚDRŽBE A POUŽITÍ ODSAVAČE PAR  
 ИНСТРУКЦИЯ ПО ПРОИЗВОДСТВУ МОНТАЖА, КОНСЕРВАЦИИ И ПОЛЬЗОВАНИЯ  
 ВЫТЯЖНЫМ УСТРОЙСТВОМ  
 油烟机安装、维护及使用指南  
 ІНСТРУКЦІЯ З ІНСТАЛЯЦІЇ, КОНСЕРВАЦІЇ ТА ЕКСПЛУАТАЦІЇ ВИТЯЖКИ ДИМОХІДНА МОДЕЛЬ

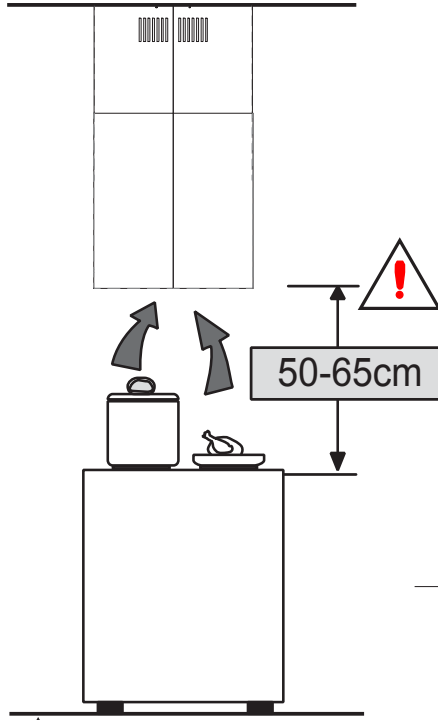

**65cm:**  
 Distanza per piani a gas  
 Distance for the gas hobs  
 Distance à respecter pour plaque de cuisinière à gaz  
 Abstand für Gaskochstellen

**50cm:**  
 Distanza per piani elettrici  
 Distance for the electric hobs  
 Distance à respecter pour plaque de cuisinière électrique  
 Abstand für Elektrokochstellen

**(A)**

Depurante	re-circulation
reinigend	Dépurant
Depurante	Depurante
Očičujuća	Til cirkulation
Suodatus	Φίλτρο καθαρισμού
Filterring	Filterkap
Oczyszczająca	De curățire
Filtrirajuća	Čistiaci (filtračný)
Čistilna	Rening
Tisztító	Čisticí
Очистная	内部循环
Очищення	

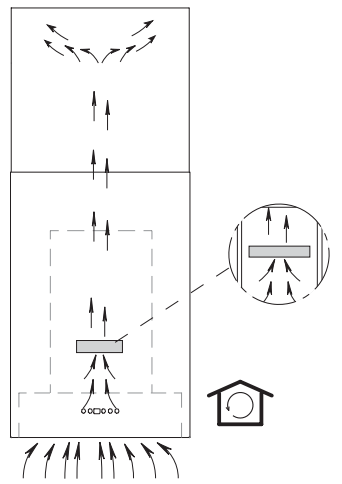

**(B)**

Aspirante	ducted outside
absaugend	Aspirant
Aspirante	Exaustora
Uisna	Til indsgning
Imu	Απορρόφηση
Suging	Zuigkap
Ssąca	De aspirare
usisavajúca	Sací (odsávaci)
Vsisalna	Insugning
Szívó	Odsávaci
Отсасывающая	对外排放
Смоктяня	

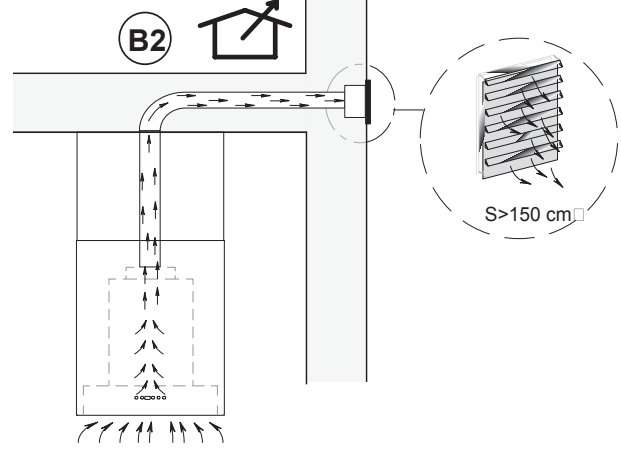
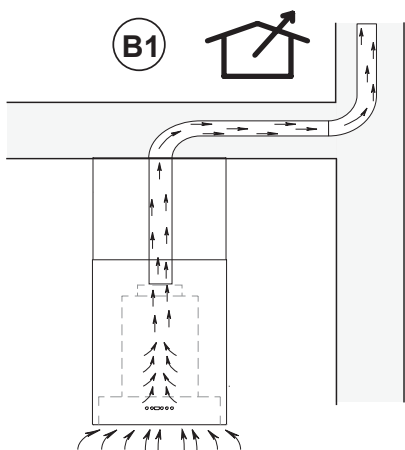

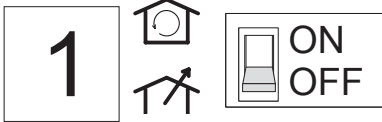

Targhetta matricola e dati tecnici  
 Typschild  
 Placa y datos técnicos  
 Tvornička tablica i tehnički podaci  
 Sarjanumero- ja arvokilpi.  
 Plate med serienummer og tekniske data  
 Tabliczka z numerem seryjnym i danymi technicznymi  
 Tabla sa serijskim brojem i tehničkim podacima  
 Tvorniška tablica in tehnični podatki  
 A gyártási számot valamint a műszaki adatokat tartalmazó tábla.  
 Щиток с серийным номером и техническими данными  
 Табличка із серійним номером і технічними даними

rating plate  
 Plaque signalétique et données techniques  
 placa de indentificação de matrícula e dados técnicos  
 Skilt med serienummer og tekniske data  
 Πινακίδιο χαρακτηριστικών και τεχνικά χαρακτηριστικά.  
 Serieplaatje met serienummer en technische gegevens  
 Tabela cu numerele de serie și datele tehnice  
 Štítok technického listu a technické údaje  
 Märkplåt för tillverkningsdata och tekniska data  
 Výrobní štítek a technické údaje  
 指示铭牌

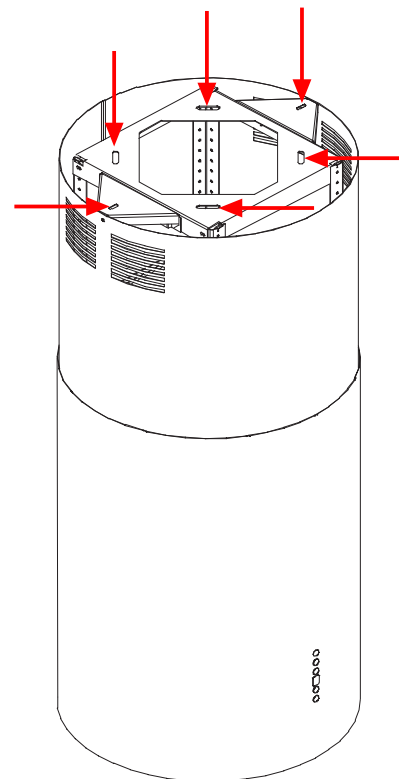
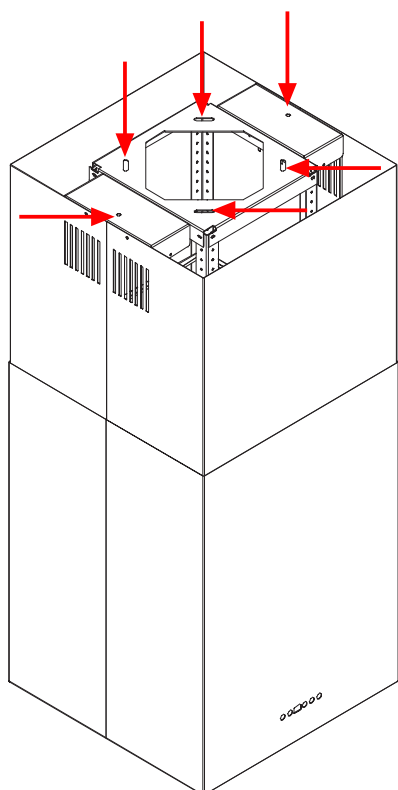
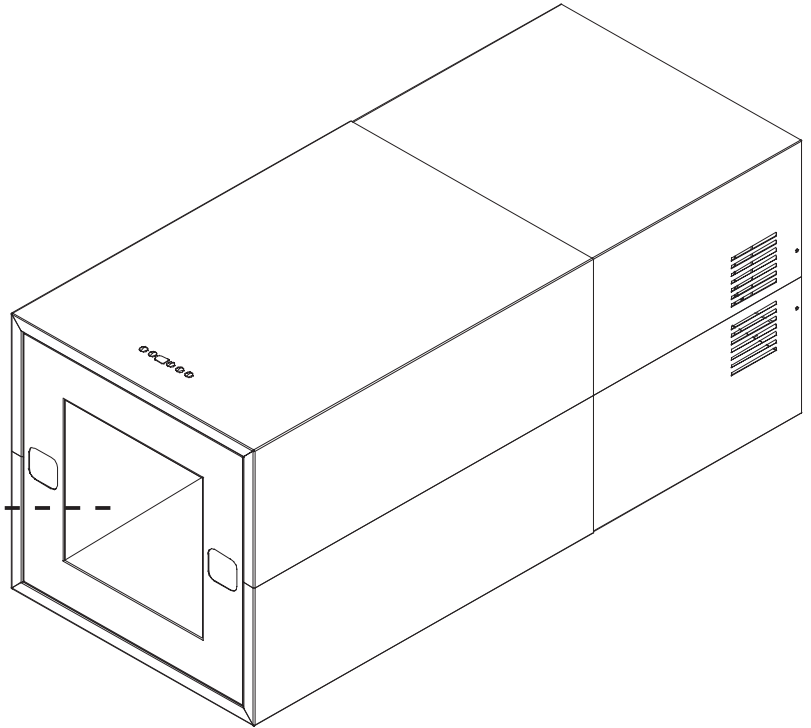
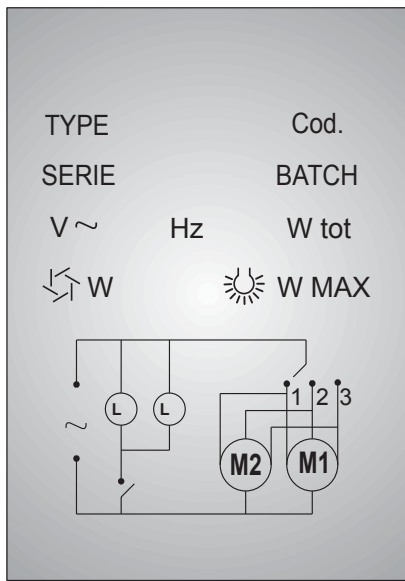

3

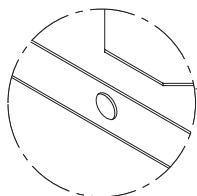
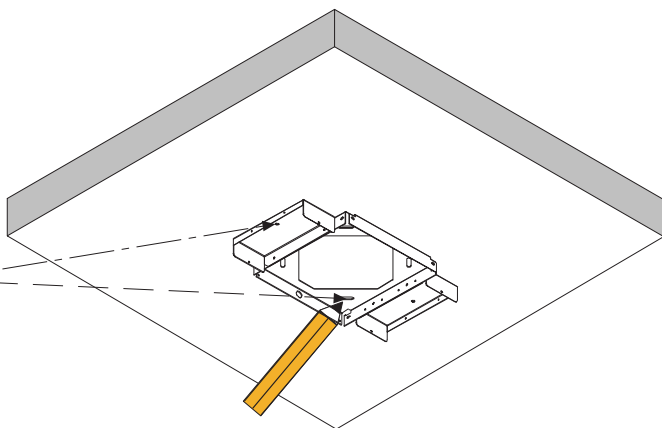
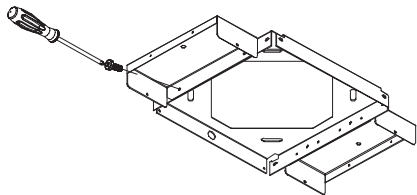

6



2

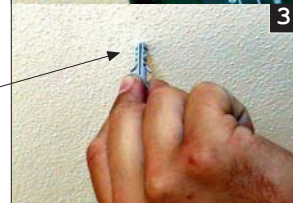

3



4



4

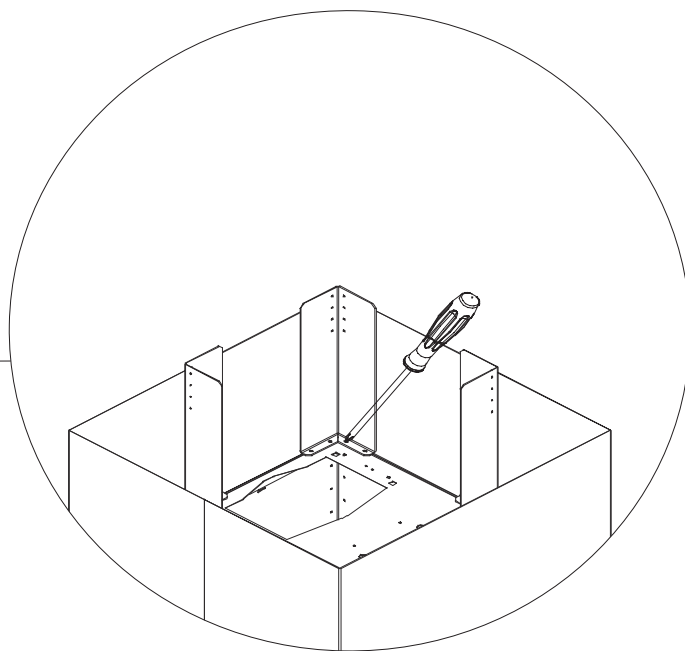
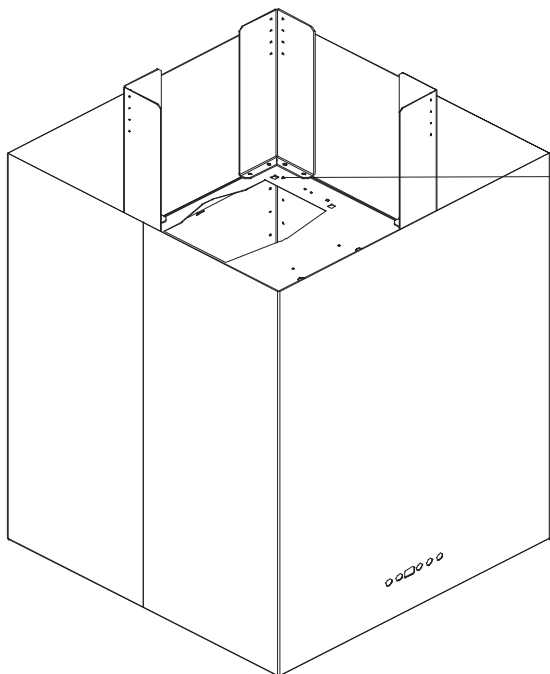
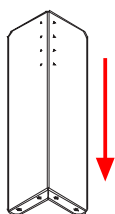

5

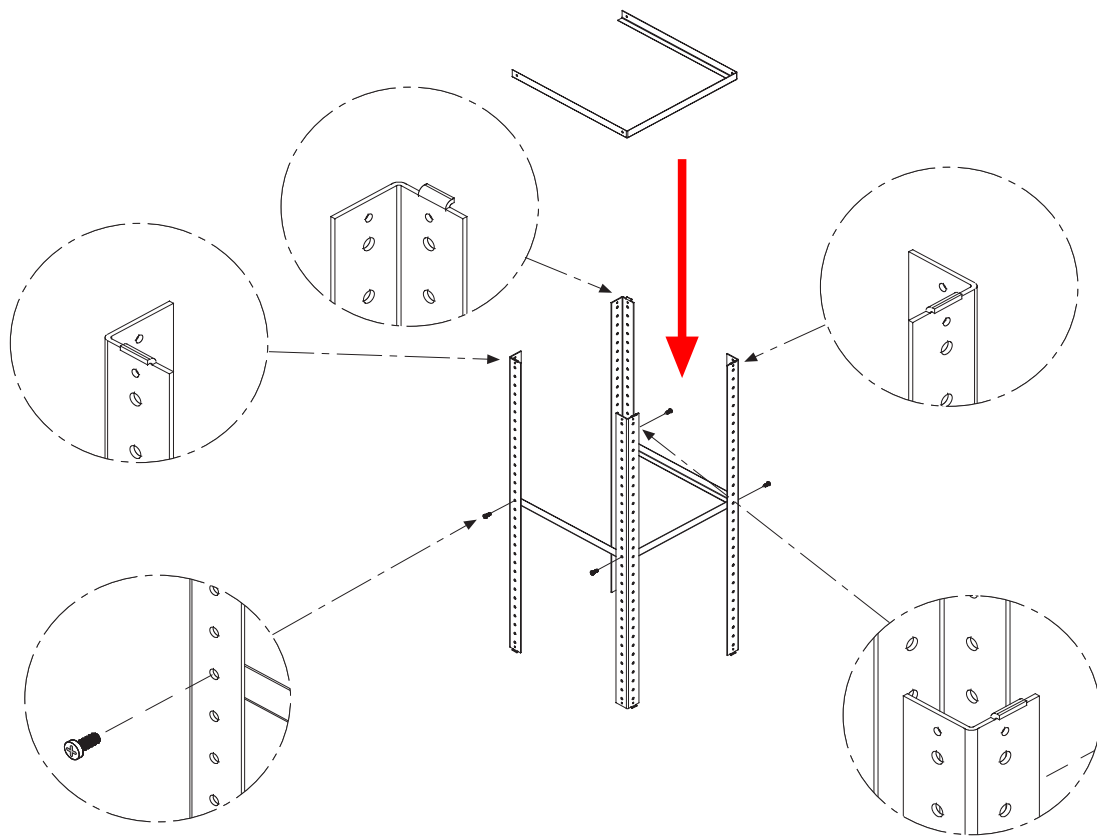

6

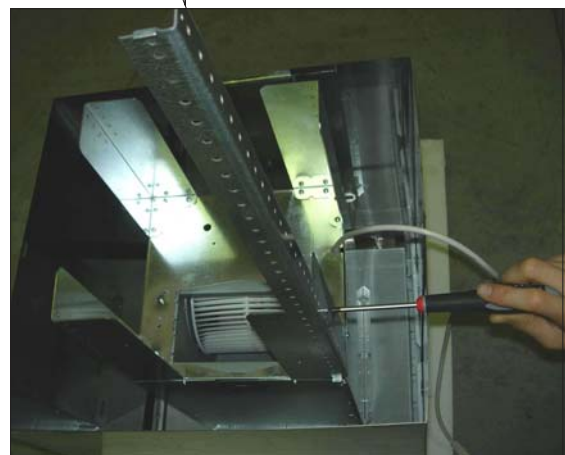
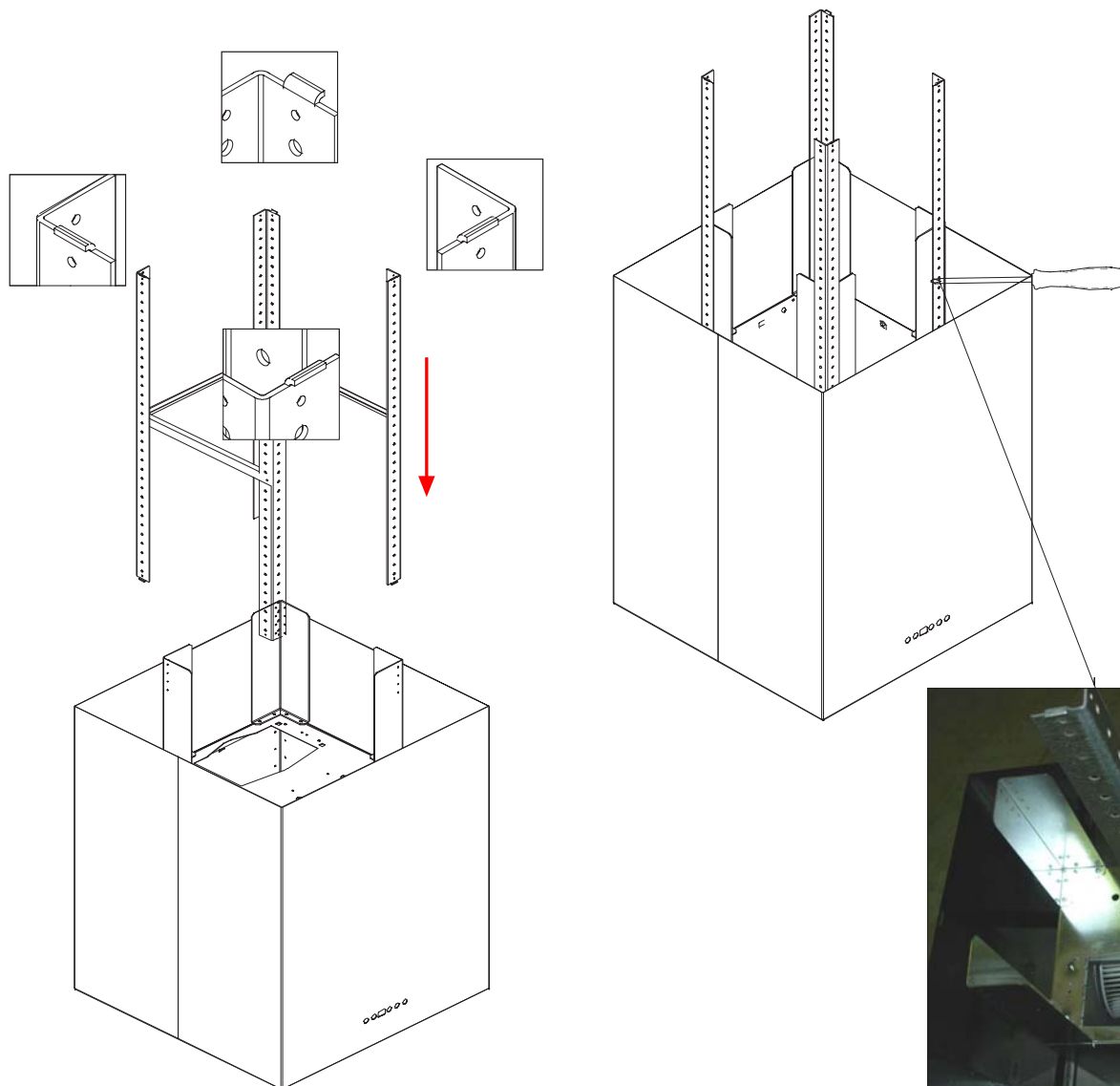

7

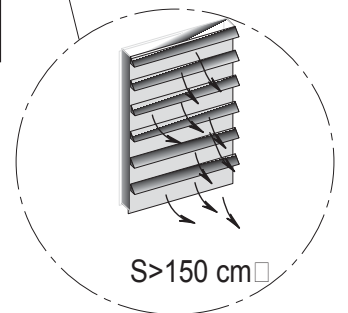
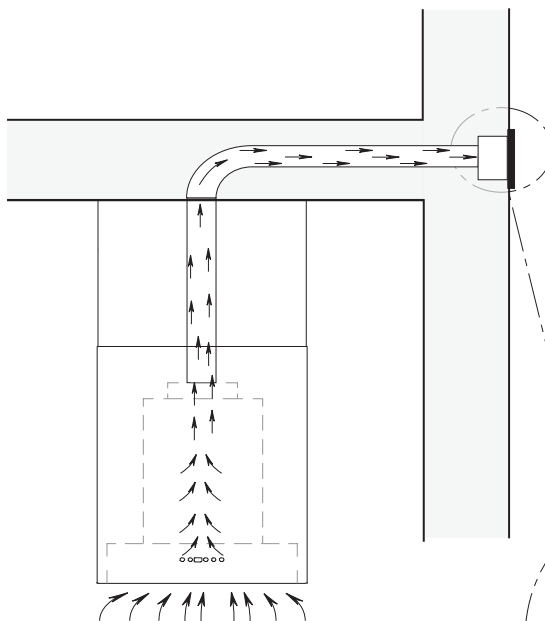
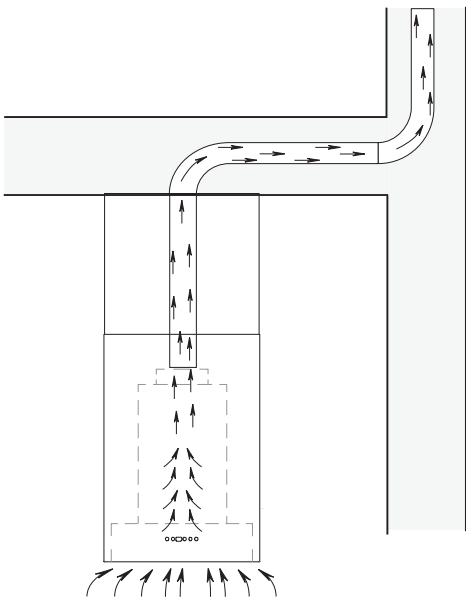
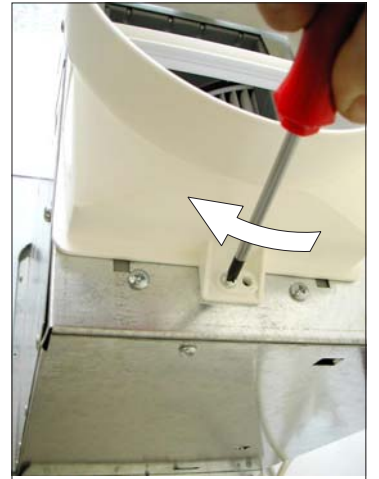
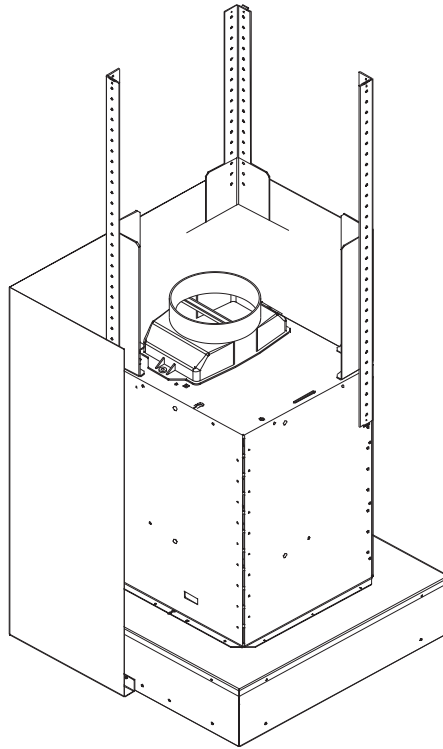
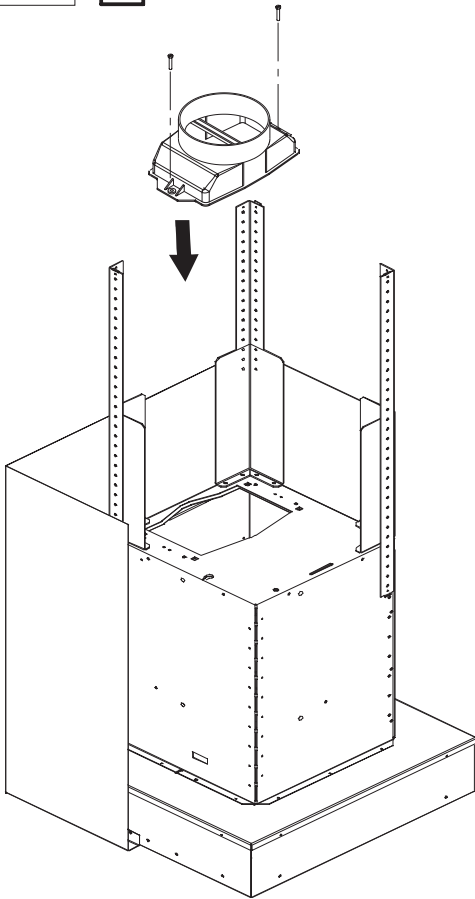

8

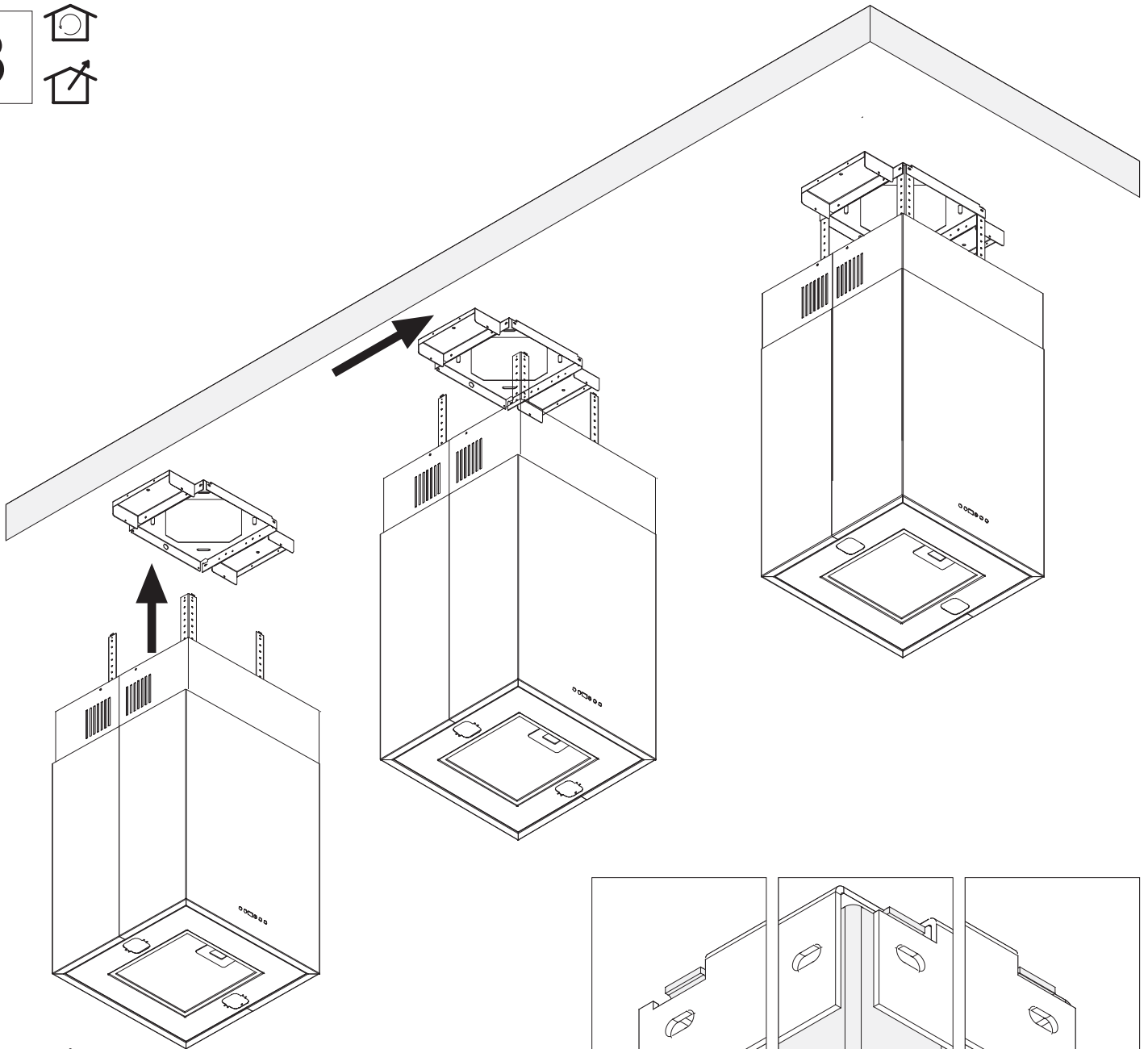

9

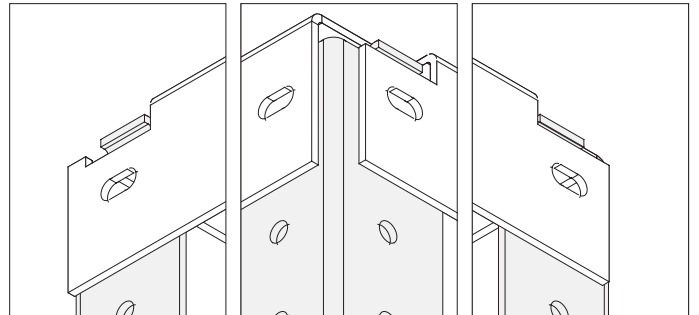
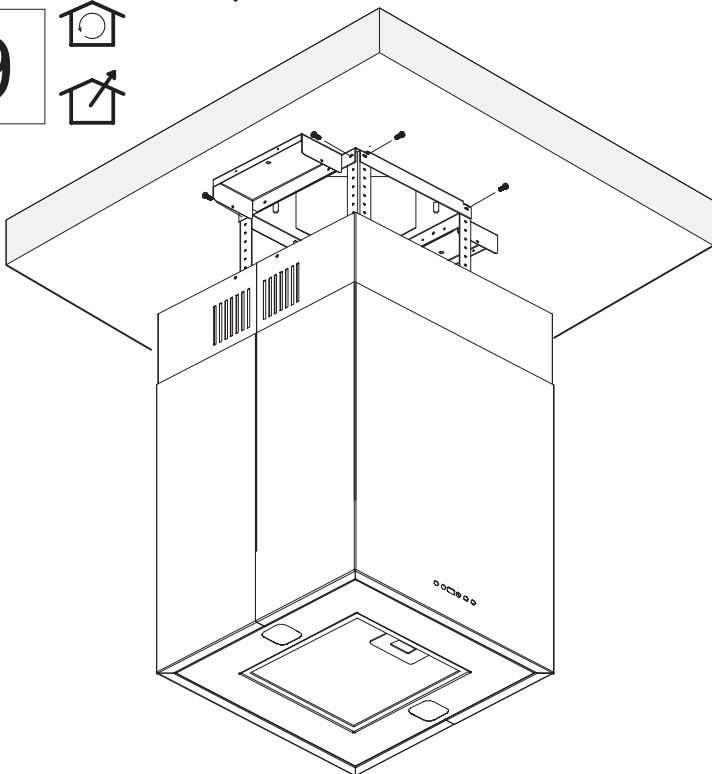

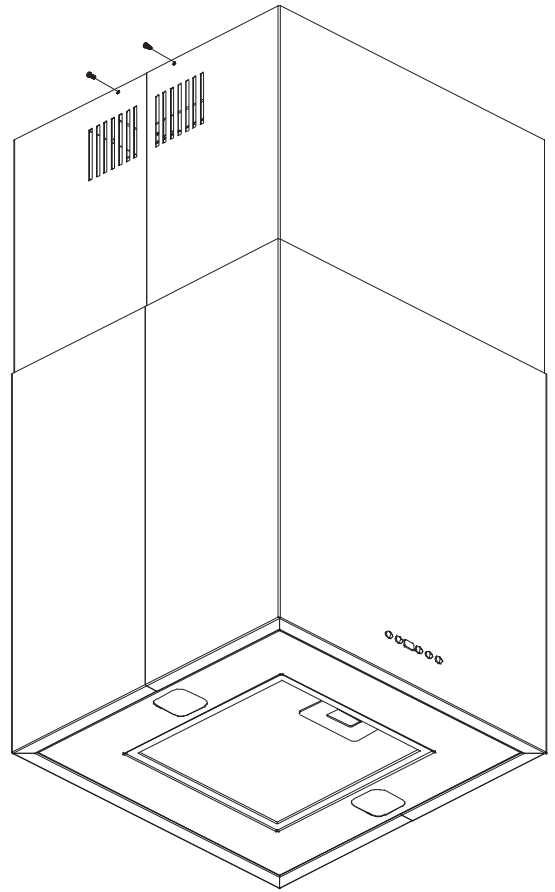
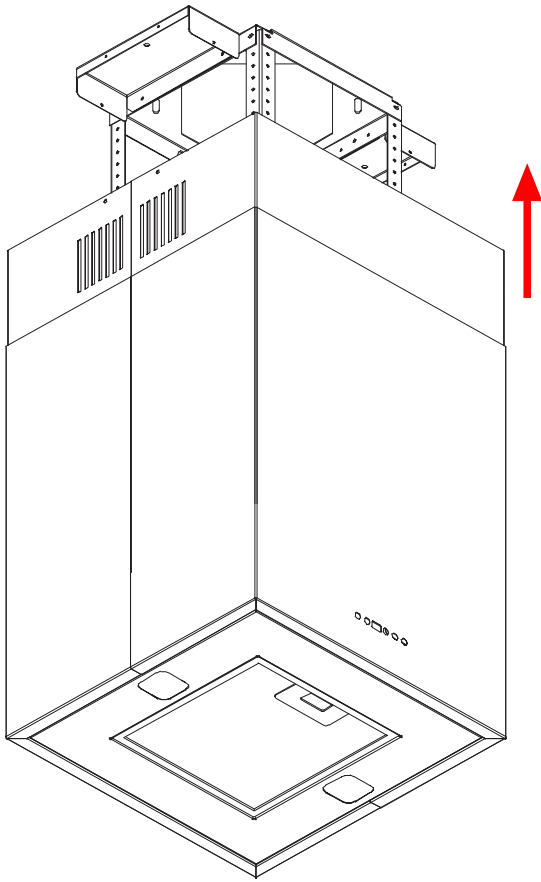



**Solo per depurante:** inserimento filtro carbone attivo  
sostituzione filtro carbone attivo ( La fornitura dei filtri di carbone attivo è opzionale )

**Only for re-circulation:** mount the charcoal filter  
replace the charcoal filter ( charcoal filters can be supplied as options )

**Nur für Reinigungsfunktion:** Aktivkohlefilter einsetzen  
Aktivkohlefilter ersetzen ( die Lieferung der Aktivkohlefilter steht wahlweise zur Verfügung )

**Uniquement pour dépurant:** insertion du filtre charbon actif  
substitution filtre charbon actif ( La fourniture des filtres au charbon actif est optionnelle )

**Sólo para depurante:** introducción filtro carbón activo  
sustitución filtro carbón activo (El suministro de los filtros de carbón activo es optativo)

**Sómente para depurantes:** inserimento filtro a carbono ativado  
-substituição filtro a carbono ativado ( o fornecimento dos filtros è opzional)

**Samo za očičujuću:** umetanje filtera na aktivni ugljen  
zamjena filtera na aktivni ugljen (Isporuka filterov na aktivni ugljen po zahtjevu)

**Kun til cirkulation:** monterning af aktivt kulfilter  
udskiftning af aktivt kulfilter (de aktive kulfiltere leveres som tilbehør)

**Ainoastaan suodatus:** aktiivihilisuodattimen asetus  
aktiivihilisuodattimen vaihto (aktiivihilisuodattimet toimitetaan lisävarusteina)

**Μόνο για το φίλτρο καθαρισμού:** προσθήκη φίλτρου ενεργού άνθρακα  
αλλαγή του φίλτρου ενεργού άνθρακα ( Η παροχή των φίλτρων είναι προαιρετική )

**Kun for filtering:** insetting av det aktive kullfilteret  
byte av det aktive kullfilteret (det aktive kullfilteret leveres som ekstrautstyr)

**Alleen voor filterkap:** de filter met actief koolstof in de kap steken  
de koolstoffilter vervangen ( De filters met actief koolstof zijn optioneel)

**Tylko dla opcji oczyszczającej:** założenie filtra z aktywnego węgla  
wymiana filtra z aktywnego węgla (Dostarczenie filtrów z węgla aktywnego jest opcjonalne)

**Doar pentru tipul de curățire:** fixarea filtrului de carbon activ  
schimbarea filtrului de carbon activ (Filtrul de carbon activ este livrat la cerere)

**Samo za opciju filtriranja:** postavljanje filtera sa aktivnim ugljem  
promena filtera (isporuka filtera je opcija)

**Len pre čistiaci (filtračný) typ prevádzky:** vloženie účinného uhoľného filtra  
výmena účinného uhoľného filtra ( Dodanie účinných uhoľných filtrov je voliteľné )

**Samo za čistilno:** vtikanje filtera na aktivni premog  
nadomeščanje filtera na aktivni premog (Ispostava filterov na aktivni premog je opcionalna)

**Endast för reningsversion:** insättning av aktivt kolfilter  
byte av aktivt kolfilter (de aktiva kolfilteren levereras som tillval)

**Csak a tisztító működési mód esetében:** az aktív szén szűrő felhelyezése  
az aktív szén szűrő cseréje (az aktív szén szűrők opcionálisan kaphatóak)

**Pouze pro čistič vzduchu:** vložení aktivního uhlíkového filtru  
výměna aktivního uhlíkového filtru (dodání aktivních uhlíkových filtrů je na objednávku)

**Только для очистного опциона:** закладка фильтра из активного угля  
обмен фильтра из активного угля (Доставка фильтров из активного угля согласно опциону)

仅用于内部循环方式: 安装炭网/更换炭网 (炭网可供选择)

**Тільки для режиму очищення:** встановлення фільтру з активного вугілля  
заміна фільтру з активного вугілля (постачання фільтрів з активного вугілля можливе за бажанням клієнта)

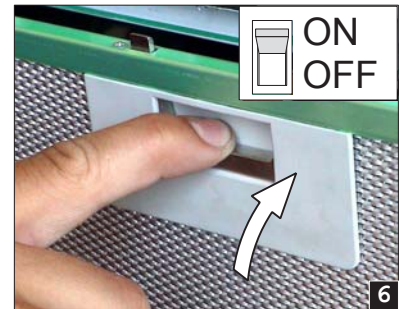
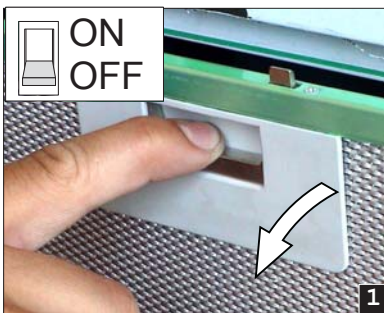
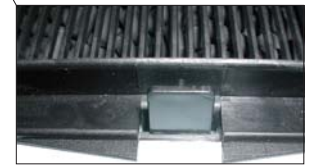
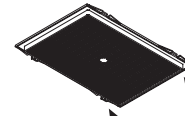
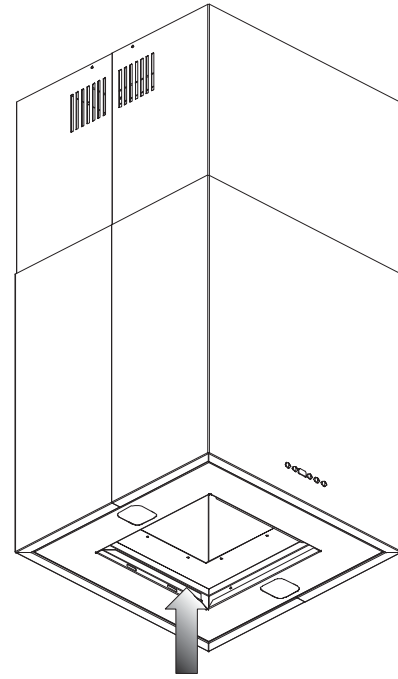

Pannello comandi  
 Painel dos comandos  
 Kontrollpanel  
 Ονίáαací panel  
 Пульá уáувлénня

Controls  
 Panel upravljánja  
 Bedieningsknoppen  
**Stikalni panel**  
 控制开关

Schaltfeld  
 betjeningspanel  
 Tablica sterownicza  
 Kontrollpanel  
 Панель уáувлénня

Tableau de commandes  
 Käyttöpaneeli  
 Tabela de comandă  
 Ιράnyító tábla

Panel mandos  
 πίνακας ελέγχου  
 Tabla za upravljanje  
 Ονίáαací panel

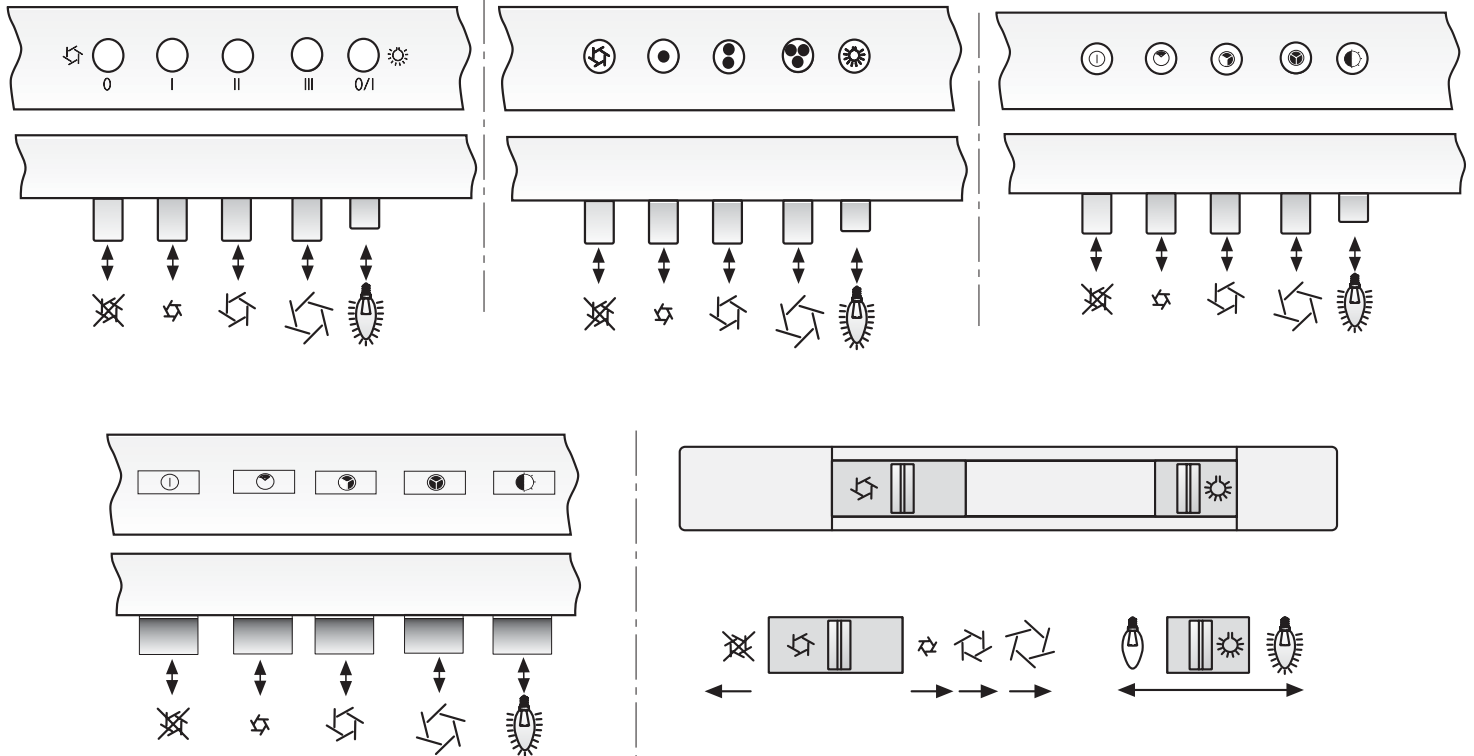

Sostituzione lampada  
 Lampenwechsel  
 Sustitución lámpara  
 Zamjena žarulje  
 Lampun vaihto  
 Bytte av lyspæren  
 Wymiana lampki  
 Promena lampice  
 Nadomeščanje žarnice  
 Lámpacsere  
 Обмен лампочки  
 Заміна лампочки

replacing lamp  
 Substitution lampe  
 Substituição lâmpada  
 Udskiftning af pære  
 Αλλαγή λάμπας  
 Het lampje vervangen  
 Schimbul lämpii  
 Výmena žiarovky (svietidla)  
 Bytte av lampra  
 Výměna žárovky  
 更換灯

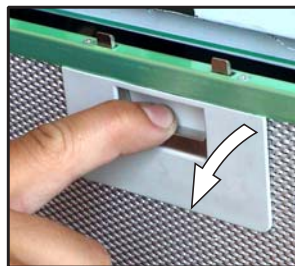

E14 11Wmax	E14 40Wmax

GU5.3 20Wmax	G4 20Wmax	E14 50Wmax	GU10 50Wmax

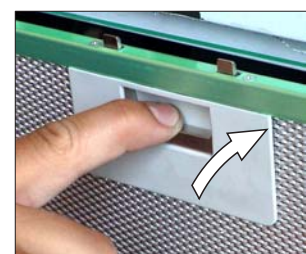
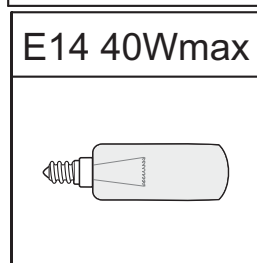

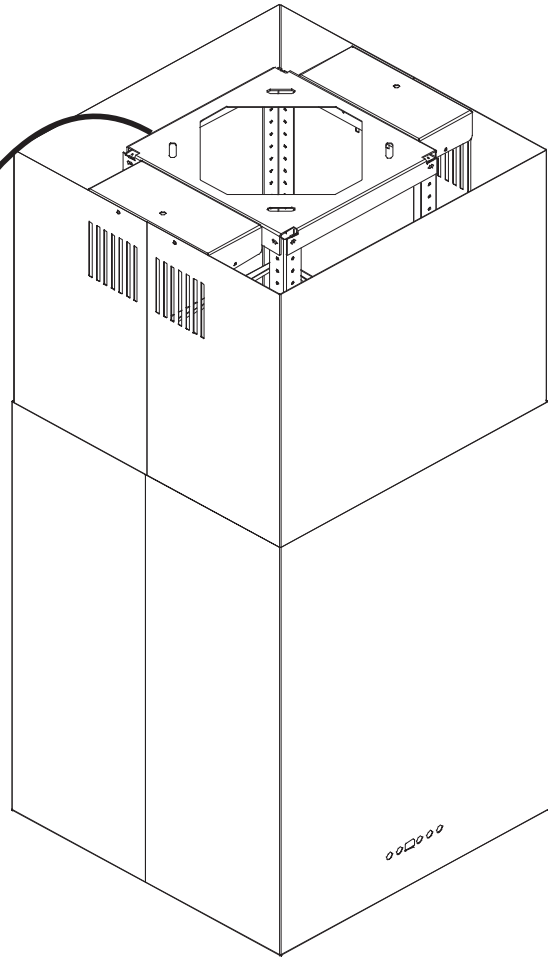
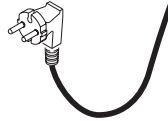
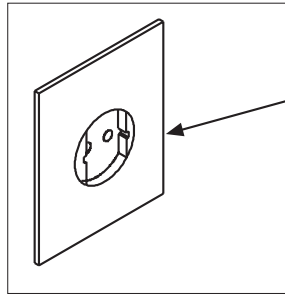

Ogni tre mesi  
Tous les trois mois  
**Svaka tri mjeseca**  
Κάθε τρεις μήνες  
Co trzy miesiące  
Každé tri mesiace  
Háromhavonta  
每三个月

Every three months  
Cada tres meses  
Hver 3. måned  
Hver 3. måned  
La fiecare trei luni  
**Vsaka tri meseca**  
Každé tři měsíce  
Кожні три місяці

Alle drei Monate  
A cada tres meses  
Kolmen kuukauden välein  
Om de drie maanden  
Svaka tri meseca  
Varje kvartal  
Каждые три месяца

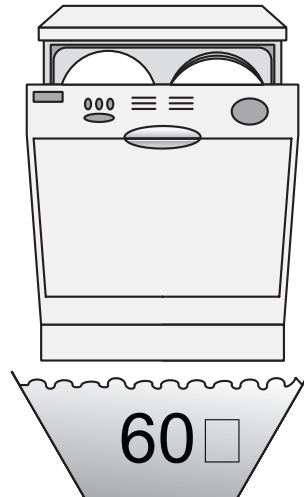
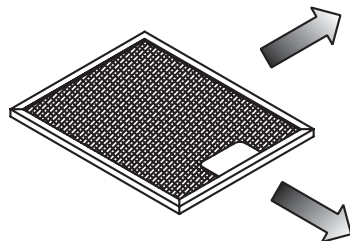
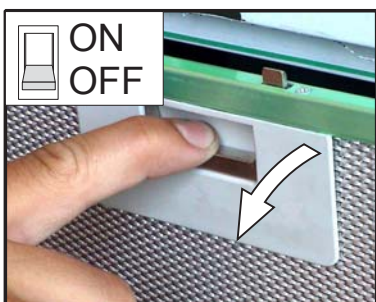

## GENERALITÀ

Prima di installare e/o usare la cappa leggere attentamente ed integralmente le istruzioni.

Prima di installare la cappa assicurarsi che la tensione (V) e la frequenza (Hz) indicati sulla targhetta matricola e dati tecnici posta all'interno dell'apparecchio corrisponda alla tensione e frequenza disponibili nel luogo d'installazione.

## INSTALLAZIONE

**In nessun caso la cappa deve essere collegata a camini di scarico di altri apparecchi alimentati con energia diversa da quella elettrica** (scaldabagni - caldaie - stufe - ecc.).

L'apparecchio non deve essere sovrapposto a stufe con piastra radiante superiore.

## COLLEGAMENTO ELETTRICO

La cappa È destinata ad essere installata in modo fisso e permanente. Collegare l'apparecchio alla rete elettrica. Per tensione di linea e frequenza consultare la targa matricola posta all'interno dell'apparecchio, avendo cura di allacciare il cavo ad una spina oppure collegare l'apparecchio ad un interruttore onipolare con una distanza di apertura dei contatti di almeno 3mm. Il cavo di alimentazione (tipo H05VV-F 2x0.75mm ) collegato ai morsetti contraddistinti con L (linea), N (neutro) della cappa e fissato con il serracavo, deve essere collegato ad un idoneo ed accessibile punto di alimentazione fisso a cura del personale specializzato ed autorizzato che deve eseguire l'installazione nel rispetto delle norme e leggi vigenti prevedendo a monte del collegamento elettrico un interruttore onnipolare con apertura dei contatti di almeno 3mm. Collegare il cavo di alimentazione, se munito di una spina, ad una presa di corrente che permette l'inserimento o il disinserimento della medesima ad apparecchio installato o ad una presa comandata da interruttore onnipolare con una distanza di apertura dei contatti di almeno 3 mm.

Il costruttore declina ogni responsabilità nel caso non vengano osservate tutte le norme antinfortunistiche vigenti e necessarie al normale esercizio e regolare funzionamento dell'impianto elettrico.

## MANUTENZIONE

Assicurarsi sempre prima di effettuare qualsiasi operazione che il cavo di alimentazione sia disinserito dalla presa di corrente o che l'interruttore sia nella posizione OFF.

**Pulizia:** Pulire le parti esterne con un panno morbido e detersivo liquido non corrosivo, evitare l'uso di polveri abrasive o di spazzole.

## AVVERTENZE

La pulitura deve venire effettuata secondo le istruzioni del costruttore specialmente riguardo ai depositi sulle superfici insudiciate contro un possibile rischio di incendio. Prestare attenzione che i fuochi siano sempre coperti in modo tale da non procurare surriscaldamento al filtro della cappa. Non friggere mai lasciando la pentola senza sorveglianza: l'olio contenuto nella pentola puŮ surriscaldarsi e incendiarsi. Nel caso di olio usato il rischio di autocombustione È piŮ elevato. È assolutamente vietato eseguire cotture con sviluppo di fiamma sotto la cappa (es. flambee). L'aria raccolta non deve essere convogliata in un condotto usato per lo scarico di fumi di apparecchi alimentati con energia diversa da quella elettrica, inoltre deve essere prevista un'adeguata aerazione del locale quando la cappa e apparecchi alimentati con energia diversa da quella elettrica vengono usati contemporaneamente. Se la cappa È utilizzata nella versione aspirante, assicurarsi delle condizioni del camino di scarico, nel caso quest'ultimo sia rimasto inutilizzato per lungo tempo. Ricordarsi di prestare attenzione alle norme vigenti locali e alle prescrizioni delle autorità competenti in merito allo scarico dell'aria da evacuare nel funzionamento aspirante della cappa. Tutti i suggerimenti dati a riguardo devono essere scrupolosamente osservati al fine di evitare possibili incendi

**IL COSTRUTTORE DECLINA OGNI RESPONSABILITÀ NEL CASO NON VENGANO OSSERVATE LE INDICAZIONI QUI SOPRA DESCRITTE IN MERITO AD INSTALLAZIONE, MANUTENZIONE ED IDONEO UTILIZZO DELLA CAPPA**

## GENERAL GUIDELINES

Before installing and / or using the cooker hood carefully read all the instructions.

Before installing the cooker hood make sure the voltage (V), frequency (Hz) indicated on the serial number plate and specifications on the rating plate on the inside of the cooker hood correspond to the voltage and frequency of the mains supply.

## INSTALLATION

**The cooker hood must not be installed and connected to flues where other appliances are installed and which run off other energy supplies different to electricity** (water heaters - boilers ñ cookers (range/agas) - etc.).

The cooker hood must not be installed above cookers with eye-level grills.

## ELECTRICAL CONNECTION

This cooker hood is designed for permanent fixture. Connect to mains supply. Check voltage and frequency given on the rating plate located on the inside of the hood. Connect the mains cable to a power socket or to a omnipolar switch with a contact gap of at least 3 mm. The mains cable (type H05VV-F 2 x0.75 mm<sup>2</sup>) is connected to terminals marked with the letters L (power line) and N (neutral) mounted on the hood and is secured in position by a cable gland. The mains cable must be connected to a suitable and easily accessible fixed power point. As the electrical installation must comply with the laws and regulations in force only a qualified and authorised electrician must install the hood including connecting it to a omnipolar switch with a contact gap of at least 3 mm.

Connect the mains cable if provided with a plug to a power socket. The user must have access to the power socket to be able to connect and disconnect the plug once the hood is mounted and fixed or the mains cable can be plugged into a socket with a omnipolar switch with a contact gap of at least 3 mm.

The manufacturer shall decline all responsibility if the governing health and safety laws are not observed which permit a safe and correct use of the hood and electrical connections.

## MAINTENANCE

Before servicing or repairing the hood make sure the appliance is disconnected from the mains supply either by removing the plug or switching the power socket to OFF.

**Cleaning:** clean the outer part of the hood with a soft cloth and liquid detergent and do not use abrasive cleaning products or scouring pads.

## WARNINGS

**"Warnings areas behind filters are not intended to be cleaned"**

Follow the cleaning instructions given by the manufacturer and in particular take care that there are no grease deposits on the surface of the hood which could create a possible fire hazard. Make sure the electric hob rings or gas rings are always covered when in use to avoid heating the filter. When frying never leave pans unattended as there is the risk of the oil overheating and catching fire. If reusing frying oil the fire risk is greater. Never prepare flambÈ (flame cooked food) dishes under the hood. The air ducted by the hood must not be conveyed into a flue used for other appliances that run off other energy supplies different to electricity. The kitchen must have good air ventilation when the hood and other appliances which run off other energy sources are in use. If the air is to be ducted, before installing make sure the flue is in good condition especially if it has been out of use for a long period of time. Always observe governing laws and regulations regarding ducting waste gases. All recommendations given must be scrupulously observed to avoid any possible fire hazard.

**THE MANUFACTURER SHALL DECLINE ALL RESPONSIBILITY IF THE FOREGOING RECOMMENDATIONS AND INSTRUCTIONS REGARDING INSTALLATION, MAINTENANCE AND USE ARE NOT OBSERVED AND RESPECTED WHEN USING THE COOKER HOOD.**

#### D

In Übereinstimmung mit den Anforderungen der Europäischen Richtlinie 2002/96/EG über Elektro- und Elektronik-Altgeräte (WEEE) ist vorliegendes Gerät mit einer Markierung versehen. Sie leisten einen positiven Beitrag für den Schutz der Umwelt und die Gesundheit des Menschen, wenn Sie dieses Gerät einer gesonderten Abfallsammlung zuführen. Im unsortierten Siedlungsmüll könnte ein solches Gerät durch unsachgemäße Entsorgung negative Konsequenzen nach sich ziehen.



Auf dem Produkt oder der beiliegenden Produktdokumentation ist folgendes Symbol  einer durchgestrichenen Abfalltonne abgebildet. Es weist darauf hin, dass eine Entsorgung im normalen Haushaltsabfall nicht zulässig ist. Entsorgen Sie dieses Produkt im Recyclinghof mit einer getrennten Sammlung für Elektro- und Elektronikgeräte. Die Entsorgung muss gemäß den örtlichen Bestimmungen zur Abfallbeseitigung erfolgen. Bitte wenden Sie sich an die zuständigen Behörden Ihrer Gemeindeverwaltung, an den lokalen Recyclinghof für Haushaltsmüll oder an den Händler, bei dem Sie dieses Gerät erworben haben, um weitere Informationen über Behandlung, Verwertung und Wiederverwendung dieses Produkts zu erhalten.

#### NL

Dit apparaat is voorzien van het merkteken volgens de Europese richtlijn 2002/96/EG inzake Afgedankte elektrische en elektronische apparaten (AEEA). Door ervoor te zorgen dat dit product op de juiste manier als afval wordt verwerkt, helpt u mogelijk negatieve consequenties voor het milieu en de menselijke gezondheid te voorkomen die anders zouden kunnen worden veroorzaakt door onjuiste verwerking van dit product als afval.



Het symbool  op het product of op de bijbehorende documentatie geeft aan dat dit product niet als huishoudelijk afval mag worden behandeld. In plaats daarvan moet het worden afgegeven bij een verzamelpunt voor recycling van elektrische en elektronische apparaten. Afdanking moet worden uitgevoerd in overeenstemming met de plaatselijke milieuvorschriften voor afvalverwerking. Voor nadere informatie over de behandeling, terugwinning en recycling van dit product wordt u verzocht contact op te nemen met het stadskantoor in uw woonplaats, uw afvalophaaldienst of de winkel waar u het product heeft aangeschaft.

#### S

Denna produkt är märkt enligt EG-direktiv 2002/96/EEC beträffande elektriskt och elektroniskt avfall (Waste Electrical and Electronic Equipment, WEEE). Genom att säkerställa en korrekt kassering av denna produkt bidrar du till att förhindra potentiella, negativa konsekvenser för vår miljö och vår hälsa, som annars kan bli följden om produkten inte hanteras på rätt sätt.



Symbolen  på produkten, eller i medföljande dokumentation, indikerar att denna produkt inte får behandlas som vanligt hushållsavfall. Den skall i stället lämnas in på en lämplig uppsamlingsplats för återvinning av elektrisk och elektronisk utrustning. Produkten måste kasseras enligt lokala miljöbestämmelser för avfallshantering. För mer information om hantering, återvinning och återanvändning av denna produkt, var god kontakta de lokala myndigheterna, ortens sophanteringstjänst eller butiken där produkten inhandlades.

#### GB

This appliance is marked according to the European directive 2002/96/EC on Waste Electrical and Electronic Equipment (WEEE). By ensuring this product is disposed of correctly, you will help prevent potential negative consequences for the environment and human health, which could otherwise be caused by inappropriate waste handling of this product.



The symbol  on the product, or on the documents accompanying the product, indicates that this appliance may not be treated as household waste. Instead it shall be handed over to the applicable collection point for the recycling of electrical and electronic equipment. Disposal must be carried out in accordance with local environmental regulations for waste disposal. For more detailed information about treatment, recovery and recycling of this product, please contact your local city office, your household waste disposal service or the shop where you purchased the product.

#### E

Este aparato lleva el marcado CE en conformidad con la Directiva 2002/96/EC del Parlamento Europeo y del Consejo sobre residuos de aparatos eléctricos y electrónicos (RAEE). La correcta eliminación de este producto evita consecuencias negativas para el medioambiente y la salud.



El símbolo  en el producto o en los documentos que se incluyen con el producto, indica que no se puede tratar como residuo doméstico. Es necesario entregarlo en un punto de recogida para reciclar aparatos eléctricos y electrónicos. Deséchelo con arreglo a las normas medioambientales para eliminación de residuos. Para obtener información más detallada sobre el tratamiento, recuperación y reciclaje de este producto, póngase en contacto con el ayuntamiento, con el servicio de eliminación de residuos urbanos o la tienda donde adquirió el producto.

#### P

Este aparelho está classificado de acordo com a Directiva Europeia 2002/96/EC sobre Resíduos de equipamento eléctrico e electrónico (REEE). Ao garantir a eliminação adequada deste produto, estará a ajudar a evitar potenciais consequências negativas para o ambiente e para a saúde pública, que poderiam derivar de um manuseamento de desperdícios inadequado deste produto.



O símbolo  no produto, ou nos documentos que acompanham o produto, indica que este aparelho não pode receber um tratamento semelhante ao de um desperdício doméstico. Pelo contrário, deverá ser depositado no respectivo centro de recolha para a reciclagem de equipamento eléctrico e electrónico. A eliminação deverá ser efectuada em conformidade com as normas ambientais locais para a eliminação de desperdícios. Para obter informações mais detalhadas sobre o tratamento, a recuperação e a reciclagem deste produto, contacte o Departamento na sua localidade, o seu serviço de eliminação de desperdícios domésticos ou a loja onde adquiriu o produto.

#### F

Cet appareil porte le symbole du recyclage conformément à la Directive Européenne 2002/96/CE concernant les Déchets d'Équipements Électriques et Électroniques (DEEE ou WEEE). En procédant correctement à la mise au rebut de cet appareil, vous contribuerez à empêcher toute conséquence nuisible pour l'environnement et la santé de l'homme.



Le symbole  présent sur l'appareil ou sur la documentation qui l'accompagne indique que ce produit ne peut en aucun cas être traité comme déchet ménager. Il doit par conséquent être remis à un centre de collecte des déchets chargé du recyclage des équipements électriques et électroniques. Pour la mise au rebut, respectez les normes relatives à l'élimination des déchets en vigueur dans le pays d'installation. Pour obtenir de plus amples détails au sujet du traitement, de la récupération et du recyclage de cet appareil, veuillez vous adresser au bureau compétent de votre commune, à la société de collecte des déchets ou directement à votre revendeur.